

# **MAGNUM 610E PUMP Oscillator Controlled**

---

## **Operation / Maintenance Manual**

---

# CONTENTS

---

<b>1</b>	<b>INSTALLATION .....</b>	<b>3</b>
1.1	UNPACKING .....	3
1.2	UTILITIES / HOOK-UP FOR 610E PUMP .....	3
1.3	UTILITIES / HOOK-UP FOR REMOTE CONTROLLER .....	4
1.3.a	Trebor's Remote Oscillator .....	4
1.3.b	Electronic Oscillation Controller (example) .....	5
1.3.c	Fiber Optic End-of-Stroke Detection .....	6
<b>2</b>	<b>OPTIONS .....</b>	<b>7</b>
2.1	FLUID PORT CONNECTION OPTIONS .....	7
2.2	HOOK-UP WITH SURGE SUPPRESSOR .....	7
<b>3</b>	<b>START-UP .....</b>	<b>8</b>
3.1	HIGH TEMPERATURE OPERATION .....	8
3.2	OSCILLATOR/CONTROLLER CYCLE RATE .....	8
3.2.a	Adjustment Instructions for Trebor Pneumatic Oscillator .....	8
3.3	PERFORMANCE CHARTS .....	8
<b>4</b>	<b>MAINTENANCE .....</b>	<b>11</b>
4.1	PREVENTIVE MAINTENANCE SCHEDULE .....	11
4.1.a	Preventive Maintenance Record .....	13
4.2	RECOMMENDED SPARE PARTS .....	14
4.3	TOOLS .....	14
4.4	PARTS ILLUSTRATION .....	15
4.5	PARTS LIST .....	16
4.6	CLEAN-UP .....	16
4.7	DISASSEMBLY .....	16
4.7.a	Body Disassembly .....	17
4.8	ASSEMBLY .....	17
4.8.a	Body Assembly .....	17
4.8.b	Final Assembly .....	19
4.9	TESTING .....	19
4.9.a	Performance Test .....	19
4.9.b	Dry Pump .....	20
4.9.c	Dry Suction .....	20
<b>5</b>	<b>TROUBLESHOOTING .....</b>	<b>21</b>
<b>6</b>	<b>WARRANTY .....</b>	<b>22</b>
<b>7</b>	<b>CONTACT INFORMATION .....</b>	<b>23</b>
7.1	GENERAL CONTACT INFORMATION .....	23
7.2	TECHNICAL SUPPORT .....	23
7.3	REGIONAL REPRESENTATIVES .....	23

# 1 INSTALLATION

---

## 1.1 UNPACKING

After unpacking, the pump should be checked for any damage that may have occurred during shipment. Damage should be reported to the carrier immediately.

The following items should be included within the shipping container:

<u>Qty</u>	<u>Item</u>	<u>Description</u>
1	610E	Magnum 610E Pump
1	M610E	Operation/Maintenance Manual

## 1.2 UTILITIES / HOOK-UP FOR 610E PUMP

It is recommended that the pump be installed no more than 15° from level to maintain its self-priming ability and pumping efficiency. This pump mounts on a quick release base for easy installation.

**Air Inlet:** 1/4" NPTF (3/8" Dia. [8mm] supply tube minimum).

**Fluid Ports:** 3/4" NPT standard (other port options available). All adapter port nuts should be torqued to 40in-lbs.

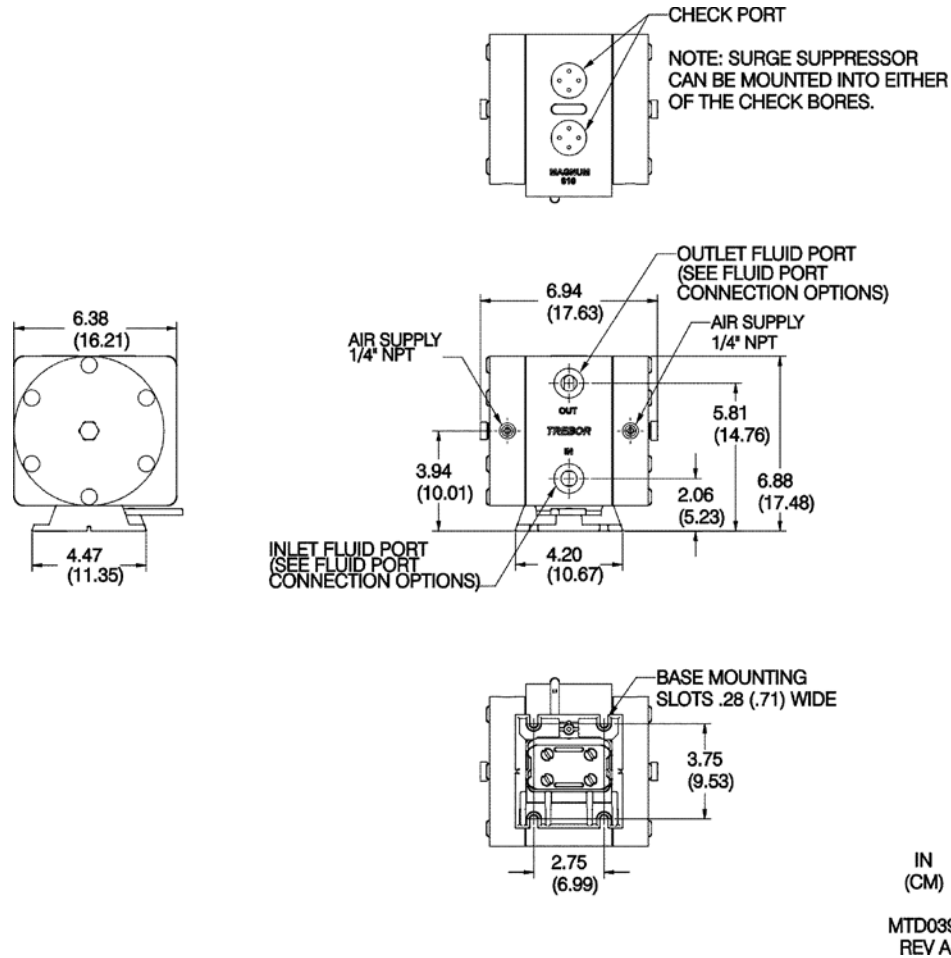

Figure 1-1

**NOTE:** It is recommended that a filter be placed on the discharge side of the pump.

**Recommended Maximum Operating Levels:** 80 psig (5.2 bar)

**ATTENTION:** The pump should be operated with clean, dry air or nitrogen. Particulate, water and oils in the air supply can damage the pump.

**NOTE:** Although extensive efforts are made to deliver pumps to our customers completely dry, new pumps may contain residual moisture from their final DI water test.

### 1.3 UTILITIES / HOOK-UP FOR REMOTE CONTROLLER

The Magnum 610E pump will work with many types of external control devices. TREBOR's pneumatic Pump Control Module is recommended for its proven, reliable performance. Please consult factory for assistance with other external control devices.

#### 1.3.a Trebor's Remote Oscillator

**Air Inlet:** 3/8" Dia. (8mm) supply tube (Use in-line 10µ air filter).

**Air Supply:** 20-80 psig (1.4 – 5.2 bar) clean dry air or nitrogen (see Performance Charts, Section 3.1, for air consumption).

The mufflers on the optional Oscillator Control Module can be removed for remote exhaust and purge connections.

**Exhaust:** 1/4" NPTF

**Purge:** 1/4" NPTF

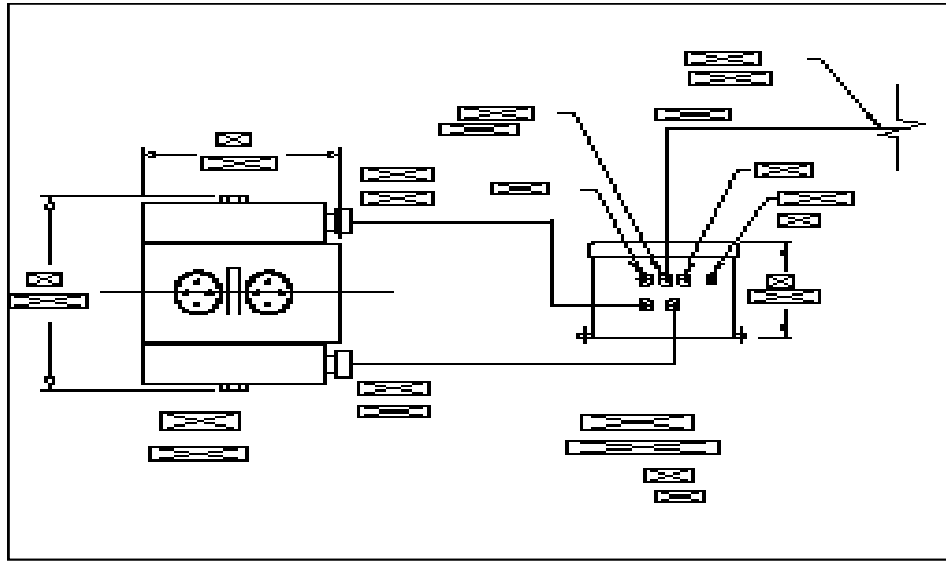

Figure 1-2

### 1.3.b Electronic Oscillation Controller (example)

**Air Inlet:** 3/8" Dia. (8mm) supply tube (Use in-line 10 $\mu$  air filter).

**Air Supply to Pump:** 20-80 psig (1.4-5.2 bar) clean dry air.

**Solenoid Valve:** C<sub>v</sub> greater than .80, 3 position.

**PLC/Electric Circuit:** For timed oscillation up to 260 cpm

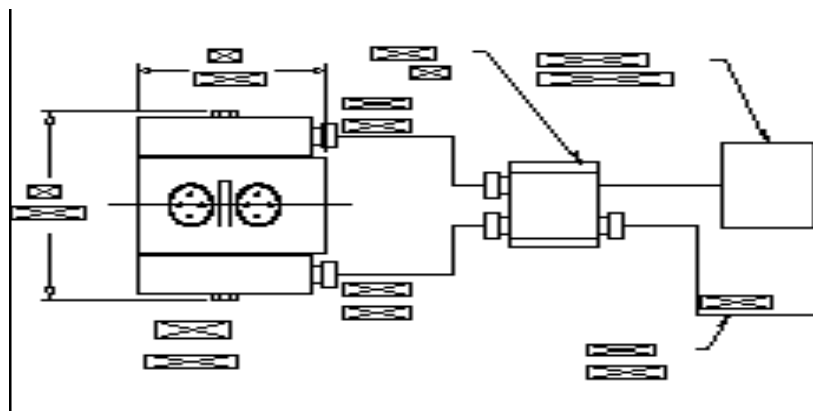
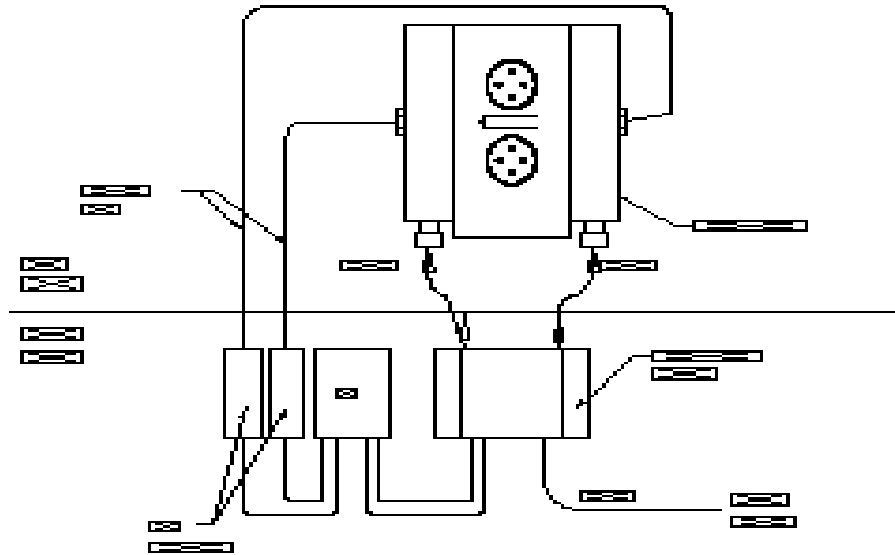

Figure 1-3

### 1.3.c Fiber Optic End-of-Stroke Detection



**Figure 1-4: Shown with Sensors and PLC Connection**

## 2 OPTIONS

### 2.1 FLUID PORT CONNECTION OPTIONS

**NOTE:** Use O-ring to seal stainless steel or other rigid plumbing.

Available Options

1/2" Flaretek (tube adapters)

3/4" Flaretek (tube adapters)

3/4" PFA (stubout tube)

1/2" Purebond (pipe)

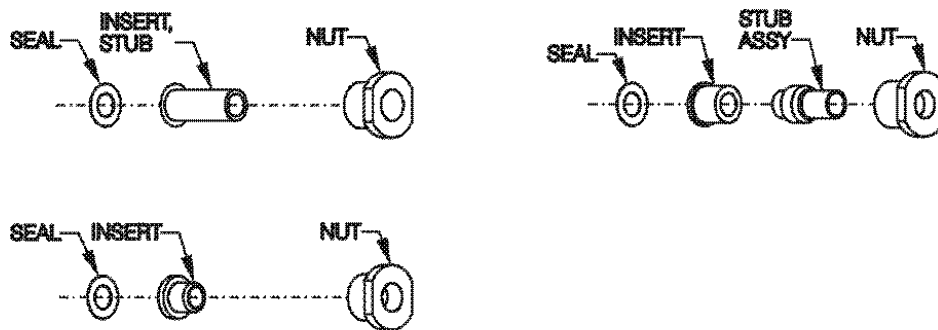

MTD0298

Figure 2-1

### 2.2 HOOK-UP WITH SURGE SUPPRESSOR

<u>Surge Suppressor</u>	<u>Assembled Height: IN (CM)</u>
SS75	12.29 (31.21)
SS85	14.82 (37.65)
SS40	12.37 (31.43)

**NOTE:** See Surge Suppressor Operation Manual for detailed installation instructions.

## 3 START-UP

---

- Pump air supply pressure should be regulated.
- Open the fluid suction (IN) line valve, if necessary.
- Open the fluid discharge (OUT) line valve, if necessary.
- Start with air regulator at low (> 15 psi) pressure setting. Increase pressure to attain desired flow, up to the maximum rating (See Section 3.2).
- Table 1: Consumption / Efficiency can be used to determine approximate air consumption.
- Refer to Troubleshooting, Section 5, if pump fails to start.

**ATTENTION:** Prolonged periods (> 5 minutes) of dry running will damage critical internal pump parts.



**CAUTION:** When handling potentially dangerous fluids under pressure, the pump and its fittings should be placed in an enclosure.

### 3.1 HIGH TEMPERATURE OPERATION

Pump operation at temperatures above 60°C requires periodic tightening of the tie bolt nuts. The frequency of this procedure is best established by the user. Refer to Section 4 on Maintenance.

### 3.2 OSCILLATOR/CONTROLLER CYCLE RATE

Applications with low flow or highly viscous fluid may require a slower cycle rate for increased efficiency. A slower cycle rate will also decrease air consumption.

#### 3.2.a Adjustment Instructions for Trebor Pneumatic Oscillator

- Remove access plug from the pump control module cover.
- Rotate adjustment knob with screwdriver.
- Rotate CW (Clockwise) to slow cycle rate.
- Rotate CCW (Counter-clockwise) to increase cycle rate.
- Re-install access plug.

**NOTE:** The TREBOR Pneumatic Oscillator comes pre-set from the factory to meet the flow requirements in most applications.

### 3.3 PERFORMANCE CHARTS

Pumping capacity is a function of air supply pressure and volume, suction head, suction line restrictions, discharge head, discharge line restriction, and fluid specific gravity and viscosity.

Air Supply Pressure (PSIG)	Discharge Fluid Pressure (PSIG)	Air Used (SCFM)	Cycles Per Minute	Displacement IN <sup>3</sup> Per Cycle
20	0	3.9	170	10.4
20	10	2.8	105	9.3
30	0	5.6	190	10.5
30	15	4.0	120	9.4
40	0	7.0	198	10.5
40	20	5.4	125	9.6
50	0	8.4	205	10.5
50	25	7.2	130	9.7
60	0	10.2	208	10.6
60	30	8.4	128	9.4

**Table 1: Consumption / Efficiency**

**NOTE:** Specification to be used to size regulators and control valves.

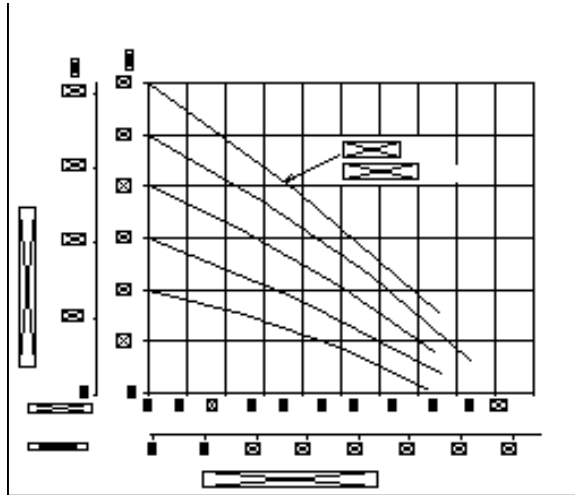

**Figure 3-1: Pressure & Capacity Chart**

**NOTE:** Test information is based on specific conditions and limited sampling. Use for general reference only. The diagram below shows the test bench layout used for ascertaining the performance information of Trebor pumps.

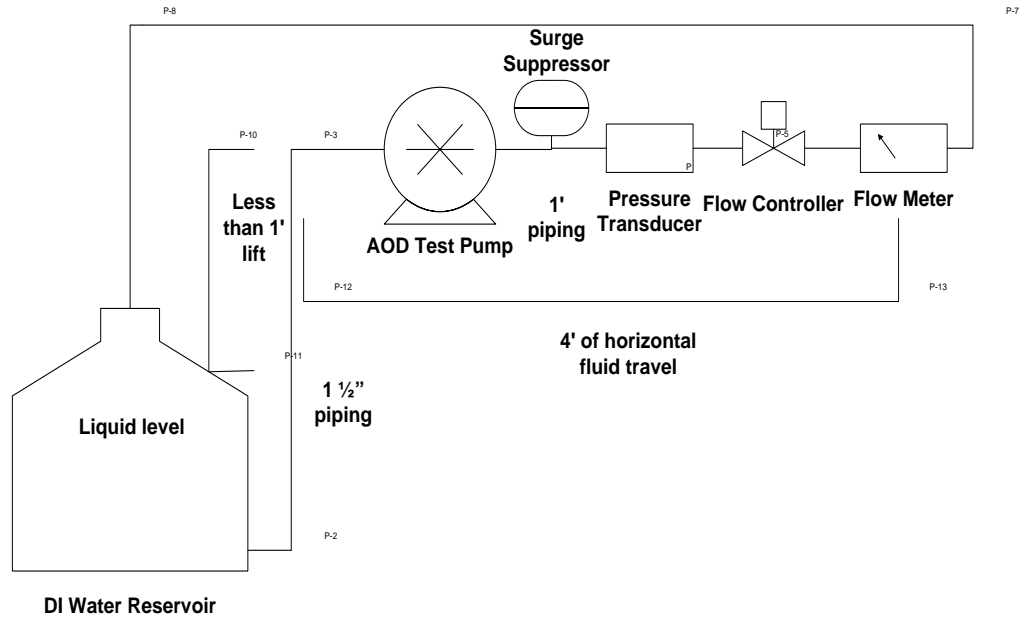

**Figure 3-2**

## 4 MAINTENANCE

Trebor pump maintenance can be divided into two categories: air system maintenance and fluid system maintenance. The purpose of air system maintenance is to prevent air system failures such as stalling or erratic cycling. The purpose of fluid system maintenance is to maintain suction and lift capabilities.

### **Pump Rebuild Service**

Trebor International provides a factory rebuild service for customers using Trebor products. Trebor will rebuild any standard pump (exclusive of options). Please contact Trebor International Sales Department for current rebuild pricing. The fixed rebuild price includes a factory rebuild and parts equivalent to the standard rebuild kit. Each factory rebuild comes with a new one-year warranty. Repairs requiring more extensive part replacements will be quoted prior to proceeding with the pump rebuild. If the pump has exceeded its useful life and cannot be rebuilt, the customer may elect to purchase a new Trebor pump. If the customer chooses not to rebuild or replace the pump, a \$150.00 evaluation charge will be required.

All returned pumps are to be shipped freight prepaid with a valid Purchase Order for the cost of rebuild service. Please contact Trebor International prior to returning your pump to obtain an RMA Number and Pump Return Data Sheet to ensure proper safety precautions. Each pump will be evaluated and repaired within 5 working days of the receipt of pump at Trebor facility.

### 4.1 PREVENTIVE MAINTENANCE SCHEDULE

The following maintenance schedule is recommended to optimize pump performance and minimize failures. Tie bolt torque should be checked within 30 days of start-up and at periodic intervals thereafter. If the pump is subjected to thermal cycle operation, the tie bolt torque should be checked after the first 3 thermal cycles and periodically thereafter. Certain operating conditions that require more frequent maintenance intervals have been noted. In positive pressure inlet conditions where suction or lift is not required, fluid system maintenance may be extended. However, tie bolt retorque is still recommended.

Adhering to the recommended preventative maintenance schedule along with periodic inspection of the pump will ensure continued efficient operation and overall reliable pump performance.

It is recommended that the Preventive Maintenance Record (Section 4.1.a) be copied, maintained and kept with this unit for future reference.

## Magnum 610E Pump

Replacement			Inspection				Component / Comments
6 Month	1 Year	2 Year	3 Month	6 Month	1 Year	2 Year	
				X			Tie Bolt Retorque (<100C)*
			X				Tie Bolt Retorque (>100C)*
		X					Check Balls and O-Rings
	X						Check Balls and O-Rings (High Suction Applications)
		X					Shaft Seal and Shaft
	X						Shaft Seal and Shaft (High Suction Applications)
		X					Diaphragms and Main Seals
	X						Diaphragms and Main Seals (H <sub>F</sub> )
X							Diaphragms and Main Seals (ACT 935 & TMAH)

\* Tie bolts must be torqued on install

**4.1.a Preventive Maintenance Record**

Company Name: \_\_\_\_\_

Company Address: \_\_\_\_\_

Product: \_\_\_\_\_ Serial Number: \_\_\_\_\_

Date: \_\_\_\_\_ Tech: \_\_\_\_\_ Notes: \_\_\_\_\_

Date: \_\_\_\_\_ Tech: \_\_\_\_\_ Notes: \_\_\_\_\_

Date: \_\_\_\_\_ Tech: \_\_\_\_\_ Notes: \_\_\_\_\_

Date: \_\_\_\_\_ Tech: \_\_\_\_\_ Notes: \_\_\_\_\_

Date: \_\_\_\_\_ Tech: \_\_\_\_\_ Notes: \_\_\_\_\_

Date: \_\_\_\_\_ Tech: \_\_\_\_\_ Notes: \_\_\_\_\_

Date: \_\_\_\_\_ Tech: \_\_\_\_\_ Notes: \_\_\_\_\_

Date: \_\_\_\_\_ Tech: \_\_\_\_\_ Notes: \_\_\_\_\_

Date: \_\_\_\_\_ Tech: \_\_\_\_\_ Notes: \_\_\_\_\_

Date: \_\_\_\_\_ Tech: \_\_\_\_\_ Notes: \_\_\_\_\_

Date: \_\_\_\_\_ Tech: \_\_\_\_\_ Notes: \_\_\_\_\_

Date: \_\_\_\_\_ Tech: \_\_\_\_\_ Notes: \_\_\_\_\_

Date: \_\_\_\_\_ Tech: \_\_\_\_\_ Notes: \_\_\_\_\_

Date: \_\_\_\_\_ Tech: \_\_\_\_\_ Notes: \_\_\_\_\_

Date: \_\_\_\_\_ Tech: \_\_\_\_\_ Notes: \_\_\_\_\_

Date: \_\_\_\_\_ Tech: \_\_\_\_\_ Notes: \_\_\_\_\_

Date: \_\_\_\_\_ Tech: \_\_\_\_\_ Notes: \_\_\_\_\_

Date: \_\_\_\_\_ Tech: \_\_\_\_\_ Notes: \_\_\_\_\_

Date: \_\_\_\_\_ Tech: \_\_\_\_\_ Notes: \_\_\_\_\_

Date: \_\_\_\_\_ Tech: \_\_\_\_\_ Notes: \_\_\_\_\_

Date: \_\_\_\_\_ Tech: \_\_\_\_\_ Notes: \_\_\_\_\_

Date: \_\_\_\_\_ Tech: \_\_\_\_\_ Notes: \_\_\_\_\_

Date: \_\_\_\_\_ Tech: \_\_\_\_\_ Notes: \_\_\_\_\_

Date: \_\_\_\_\_ Tech: \_\_\_\_\_ Notes: \_\_\_\_\_

## 4.2 RECOMMENDED SPARE PARTS

**KR610E-00-A Spares Rebuild Kit**, which includes:

<u>Part No</u>	<u>Qty</u>	<u>Description</u>	
KD610-00-A	1	<b>Diaphragm Kit</b>	
		Includes: (2) C0100	Diaphragm Sets
		(2) 98001422	Main Seals
11001015	1	Protective Cap Set	
1610B0022	1	Shaft	
98001415	4	Check Ball	
98001976	2	Shaft Seal	
98002334	4	O-Ring, PTFE	
AM084	2	Check Cap Seal	
W0151	2	Fiber Optic Target	

In critical applications, a spare pump and oscillator control module are recommended to minimize down time.

## 4.3 TOOLS

The following tool kit is recommended as standard service equipment.

**KT610E-00-A Tool Kit**, which includes:

<u>Part No</u>	<u>Qty</u>	<u>Description</u>
98001225	2	3/8" Nut Driver
98002327	1	Tool Case
98003225	1	3/8x1/4 Drive Socket
98003305	1	1/4" Drive Handle
T000B0014	1	Check Sleeve Removal Tool
T000B0020	1	Check Sleeve Insertion Tool
T0146	1	3/4" Pin Tool
T16002104	1	Shaft Bullet
T0144	1	Cleaning Tool

## 4.4 PARTS ILLUSTRATION

□ BORDERS REPRESENT FLUID CONTACT AREAS OF PUMP

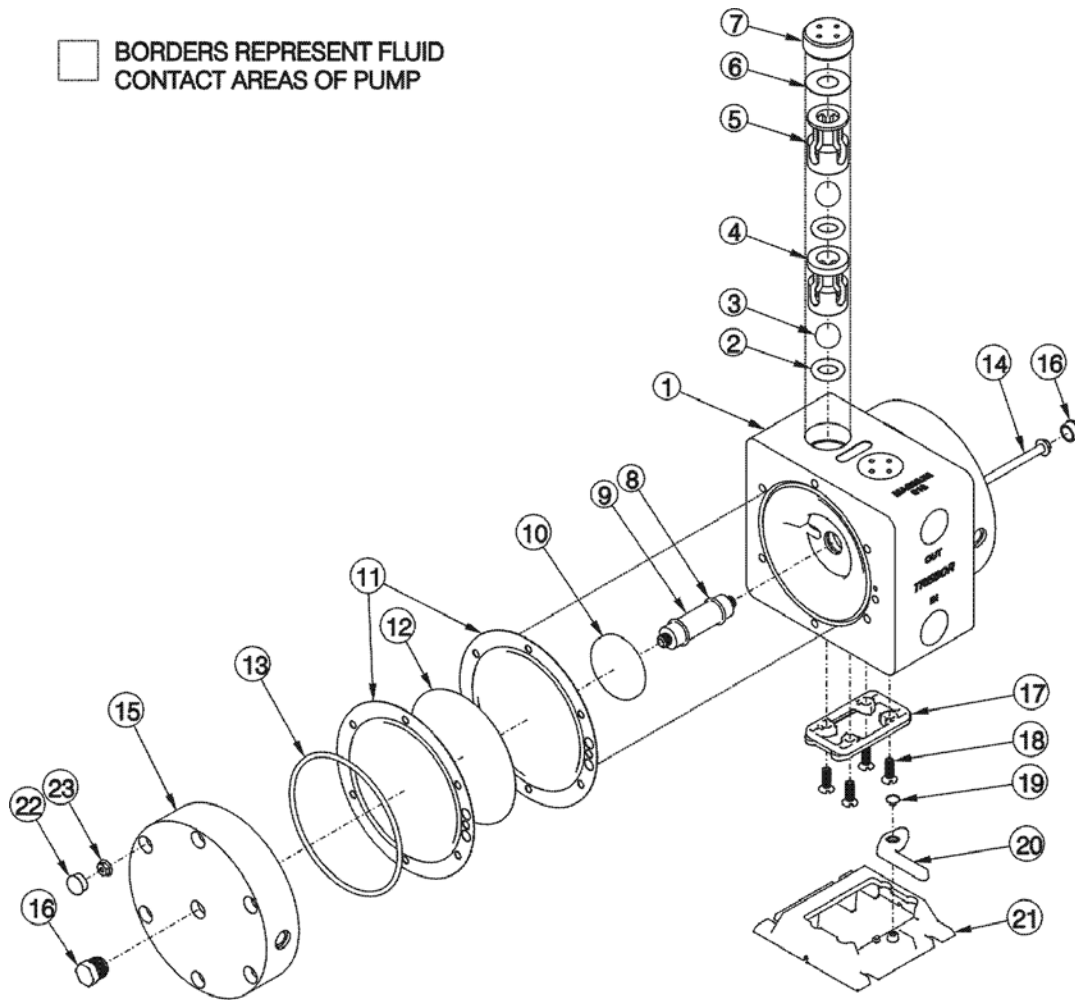

MTD0541

## 4.5 PARTS LIST

ILL NO	PART NO	QTY	DESCRIPTION	PM YEAR #	MATERIAL
1	C0104	1	Body		PTFE
2	98002334	4	O-Ring, PTFE Check Valve	2	PTFE
3	98001415	4	Check Ball	2	PTFE
4	1610B0007	2	Suction Sleeve		PTFE
5	1610B0008	2	Discharge Sleeve		PTFE
6	AM084	2	Seal	2	PTFE
7	C0133	2	Check Bore Cap		PTFE
8	98001976	2	Shaft Seal	2	PTFE
9	1610B0022	1	Shaft	2	PFA
10	C0095	2	Push Plate		PTFE
11	C0100	2	Diaphragm Set	2	PFA
12	W0151	2	Fiber Optic Target	2	PTFE
13	98001422	2	Main Seal	2	Viton
14	1110B0015	6	Tie Bolt Assembly		SS416, PFA
15	C0086	2	Head		PP
16	98001804	2	3/8" NPT Plug		PE
17	AM022	1	Base Mount		PP
18	98003207	4	Screw		PP
19	98003071	1	Screw		PP
20	AM023	1	Locking Lever		PP
21	C0102	1	Quick Release Base		PP
22	98001109	12	Tie Bolt Cap	2	PU
23	98002338	6	Nut, Flanged		SS18-8

## 4.6 CLEAN-UP

The pump fluid cavities may be flushed clean by cycling with the suction (IN) and discharge (OUT) lines connected to a DI water flushing or rinsing tank. Flushing using an external pressure source without allowing the pump to cycle will result in incomplete removal of potentially dangerous chemicals.

**NOTE:** To effectively eliminate chemical contamination, the pump should cycle for 10-15 minutes using the flushing DI water as described above.

## 4.7 DISASSEMBLY

During the life of the pump it will be necessary to perform certain preventative maintenance procedures to ensure its continued high performance. This section and the next (4.8 Assembly) are provided for the user's convenience in disassembly and re-assembly procedures.

- Thoroughly clean/flush the pump using DI water (Refer to Section 4.6 Clean-Up).
- Disconnect fluid and air connections from pump.
- Unlock pump from quick release base by pulling out locking lever on front of quick release base. Slide pump forward until it stops. Lift pump off quick release base.
- Remove 3/8" NPT plugs from heads.
- Remove tie bolt caps from both heads.
- Remove un-tact flanged nuts from the tie bolt assemblies. Using both 3/8" nut drivers. Leave tie bolts in place.

- Lay the pump on the slave head side.
- Remove the master head.
- Remove the main seal and diaphragms.
- Remove the body assembly.
- Remove the slave side set of diaphragms and main seal.
- Remove tie bolts.

**NOTE:** All polypropylene and fluoroplastic parts, when disassembled, should be thoroughly washed and be free from acid residue for handling purposes.

#### **4.7.a Body Disassembly**

- Remove check bore caps using 3/4" pin tool and remove seals.
- Remove sleeves with sleeve removal tool, check balls and O-rings.
- Unthread one push plate from the shaft.
- Remove remaining push plate and shaft from body.
- Unthread **second** push plate from shaft.
- Remove shaft seals from the shaft bore, taking care not to damage the shaft bore or shaft seal grooves.
- Remove base mount from body.

## **4.8 ASSEMBLY**

#### **4.8.a Body Assembly**

**NOTE:** For easy installation, check sleeves that fit too tightly should be placed in a freezer prior to assembly to assist insertion. Body must be upside down with check port extending over a table edge so that parts remain assembled during insertion of sleeves. (See Figure 4-1.)

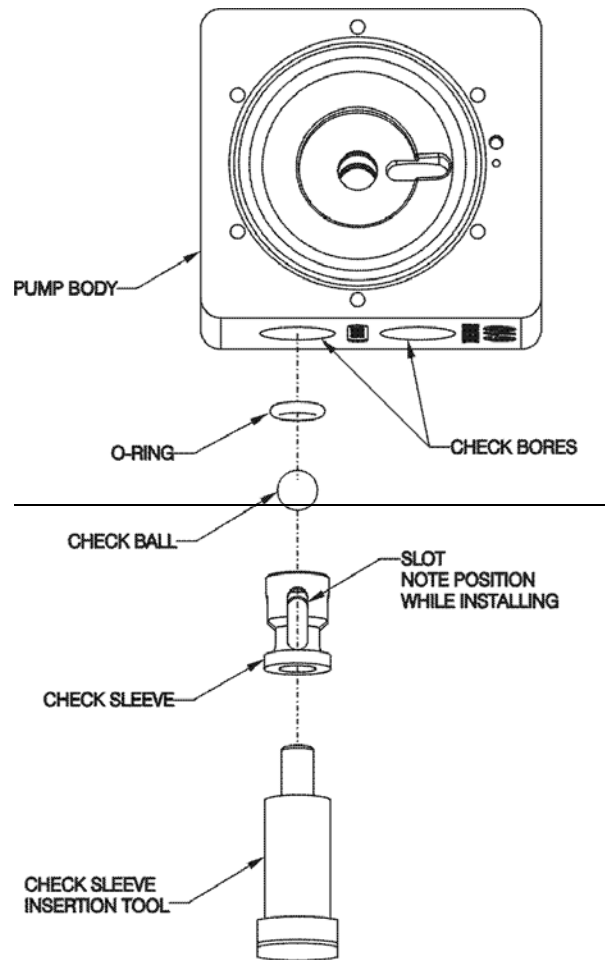

MTD0321

**Figure 4-1**

- Insert suction sleeve, check ball and O-ring carefully into check bore.

**NOTE:** The Suction Sleeves have a shoulder diameter larger than their body diameter. Additionally the Suction Sleeves when compared to the Discharge Sleeves have a thicker top region which acts as a robust contact point for the O-rings.

- Repeat insertion process with the discharge sleeve, check ball and O-ring.
- Repeat process for second check bore.
- Replace check cap seals and tighten check bore caps to 50in-lbs.
- Install shaft seals into shaft bore grooves.
- Thread shaft into push plate until engagement with the shaft shoulder is achieved. Additionally apply a ¼" turn to ensure proper installation.
- Insert shaft through shaft bore using shaft bullet as shown (This prevents damage to the TFE shaft seals and prevents dislodgement of shaft seals).

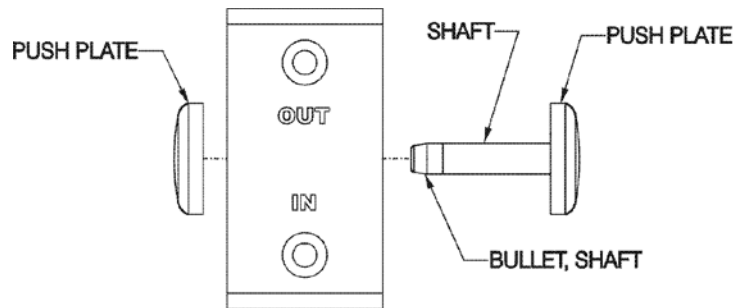

**Figure 4-2**

- Remove bullet and thread on remaining push plate, tighten per previous practice.
- Install base mount to pump using screws.

#### **4.8.b Final Assembly**

- Insert tie bolt assemblies through slave head and lay flat with tie bolts sticking up.
- Place main seal O-ring into the main seal groove in head.
- Install a diaphragm set (with PTFE target between the diaphragms), removing all air from between diaphragms, onto the tie bolts noting the relative orientation of the formed main seal groove in the diaphragms with respect to conforming to the main seal.
- Carefully place and press the body assembly onto the tie bolts.
- Install the remaining diaphragm set onto the tie bolts and body, again noting formed main seal groove.
- Place the main seal O-ring into the formed groove of the master head.
- Lift the slave head and body, while maintaining compression of the main seal, flip the head and body over and insert the tie bolts into the master head. Ensure that the main seal of the master head is not dislodged.
- Install flange nuts onto tie bolts; tighten evenly in a star pattern and torque to 42 in-lbs.
- Install tie bolt caps and 3/8" NPT fittings into each head.

## **4.9 TESTING**

### **4.9.a Performance Test**

- Start with air regulator at low (< 15 psi) pressure setting.
- Pump must prime once pressure is increased
- Increase to 60 psig Supply Pressure

- Check for fluid leaks, listen for air leaks, check for irregularity
- Prepare the pump for drying

#### **4.9.b Dry Pump**

- Connect vacuum hose to discharge line
- Connect purge line to fluid inlet
- 60 psig Supply Pressure
- Cycle pump & vacuum dry by rotating pump side to side for 30 seconds.
- Turn off Air Supply and allow the pump to purge for 5 minutes.

#### **4.9.c Dry Suction**

- 20 psig Supply Pressure Target
- Record Suction Value
- Target = 8 in-Hg.

---

## 5 TROUBLESHOOTING

---

### **Pump Will Not Start, Fails to Operate**

Cause:

- Insufficient air pressure.
- Insufficient air volume.
- Remote air logic system malfunctioning.

Solution:

- Must be 10-15 psi greater than fluid discharge line pressure.
- See Performance Charts (3.2) for requirements.
- Replace or repair air logic system.

### **Bubbles in Fluid Discharge**

Cause:

- Leaking fluid inlet fitting.
- Leaking main seal.
- Ruptured (perforated) diaphragm.

Solution:

- Tighten, or remove and wrap with TFE thread tape prior to tightening.
- Tighten tie bolt nuts to 42 in-lbs. Replace diaphragms if damaged.
- Replace Diaphragms.

### **Fluid Leaks**

Cause:

- Tie bolt torque not enough to effect seal.
- Damaged main seal.
- Check bore cap.
- Ruptured diaphragm(s) can result in fluid leaks through air exhaust port and remote air logic system.

Solution:

- Tighten all nuts to 42 in-lbs.
- Replace.  
Check for irregularities in diaphragm groove on pump body.
- Tighten, or remove and replace seal.
- Replace diaphragms, and any parts that may have been damaged by fluid exposure.

### **Erratic Cycling**

Cause:

- Check ball(s) not seating.
- Remote air logic system malfunctioning.

Solution:

- Replace check balls and O-rings.
- Replace or repair remote control air logic system.

## 6 WARRANTY



### **MAGNUM 610E PUMP**

TREBOR International, Inc. warrants to the purchaser of new equipment manufactured by TREBOR to be free from defects in material and workmanship when used for its intended purpose under normal operating conditions, and maintained according to the Operation/Maintenance Manual.

TREBOR's obligation under this warranty is limited to repairing or replacing, at TREBOR's option and at the TREBOR factory, any part or parts thereof which shall, within 1 year after delivery thereof to the original purchaser, be demonstrated to TREBOR's satisfaction to have been defective. This warranty may be transferred to subsequent owners. The warranty period is based on the original ship date from the factory. All warranty related freight costs shall be borne by the customer.

Excessive wear to pump components caused by pumping abrasive solutions or chemicals, as well as damage caused by ingesting foreign objects shall not be covered by this warranty.

This warranty shall not apply to any equipment which, in the judgment of TREBOR, shall have been repaired or altered outside TREBOR's factory in any way, so as to affect its performance or reliability; subjected to misuse, negligence or accident; or used other than in accordance with TREBOR's printed instructions.

**There are no terms, conditions or warranties, expressed, implied or statutory, of merchantability, fitness, capacity, or otherwise, of the goods ordered, other than, or different from, the warranty set forth above. This warranty takes precedence over any other warranty, expressed or implied.**

TREBOR neither assumes, nor authorizes any other party to assume for it, any liability in connection with said equipment except as set forth above.

## **7 CONTACT INFORMATION**

---

### **7.1 GENERAL CONTACT INFORMATION**

Web: [www.idex-hs.com](http://www.idex-hs.com)  
Phone Number: (801) 561-0303  
Toll Free Number: (800) 669-1303  
Fax Number: (801) 255-2312  
Email: [treborinfo@idexcorp.com](mailto:treborinfo@idexcorp.com)  
[treborsales@idexcorp.com](mailto:treborsales@idexcorp.com)  
Address: Trebor International  
8100 South 1300 West  
West Jordan, Utah 84088 U.S.A.

### **7.2 TECHNICAL SUPPORT**

Email: [treborservice@idexcorp.com](mailto:treborservice@idexcorp.com)  
Phone Number: (801) 244-6156

### **7.3 REGIONAL REPRESENTATIVES**

Web: [www.idex-hs.com/about/distributors/trebor\\_distributors.aspx](http://www.idex-hs.com/about/distributors/trebor_distributors.aspx)