

MAGNUM 610NM PUMP

Operation / Maintenance Manual

CONTENTS

1	INSTALLATION	3
1.1	UNPACKING	3
1.2	UTILITIES / HOOK-UP	3
1.3	CHECK MUFFLER OPERATION	4
1.3.a	Purpose	4
1.3.b	Adjustment.....	5
2	OPTIONS	6
2.1	FLUID PORT CONNECTION OPTIONS.....	6
2.2	HOOK-UP WITH SURGE SUPPRESSOR.....	6
3	START-UP	7
3.1	HIGH TEMPERATURE OPERATION	7
3.2	PERFORMANCE CHARTS	7
4	MAINTENANCE	9
4.1	PREVENTIVE MAINTENANCE SCHEDULE	9
4.1.a	Preventive Maintenance Record.....	11
4.2	RECOMMENDED SPARE PARTS.....	12
4.3	TOOLS.....	12
4.4	PARTS ILLUSTRATION.....	13
4.5	PARTS LIST	14
4.6	CLEAN-UP.....	14
4.7	DISASSEMBLY.....	14
4.7.a	Master and Slave Heads	15
4.7.b	Body Disassembly	15
4.8	ASSEMBLY.....	16
4.8.a	Head Assemblies.....	16
4.8.b	Body Assembly	16
4.8.c	Final Assembly	18
4.9	TESTING	19
4.9.a	Performance Test.....	19
4.9.b	Dry Pump.....	19
4.9.c	Dry Suction	19
5	TROUBLESHOOTING	20
6	WARRANTY	21
7	CONTACT INFORMATION	22
7.1	GENERAL CONTACT INFORMATION.....	22
7.2	TECHNICAL SUPPORT	22
7.3	REGIONAL REPRESENTATIVES	22

1 INSTALLATION

1.1 UNPACKING

After unpacking, the pump should be checked for any damage that may have occurred during shipment. Damage should be reported to the carrier immediately.

The following items should be included within the shipping container:

<u>Qty</u>	<u>Item</u>	<u>Description</u>
1	610NM	Magnum 610NM Pump
1	M610NM	Operation/Maintenance Manual
1	C0135	Check Muffler Assembly

1.2 UTILITIES / HOOK-UP

The pump is mounted using four 1/4" bolts. It is recommended that the pump be mounted so as to deviate no more than 15° from level to maintain its self-priming and pumping efficiency.

Air Inlet: 1/4" NPTF (3/8" Dia. [8mm] supply tube minimum).

Air Supply: 20-60 psig (1.4 – 4.1 bar) clean dry air or nitrogen. (See Performance Charts, Section 3.2 for air consumption.)

Fluid Ports: IN/OUT: 3/4" NPT All adapter port nuts should be torqued to 40in-lbs (other connection options available) **IMPORTANT SUCTION (IN) LINE REQUIREMENTS:** (for maximum flow)

1. Maximize supply line diameter.
2. Minimize supply line length.
3. Minimize supply line restrictions; valves, fittings.
4. Normal pump operation requires suction (negative fluid head) supply. See Section 1.3 for requirements of other hook-ups.

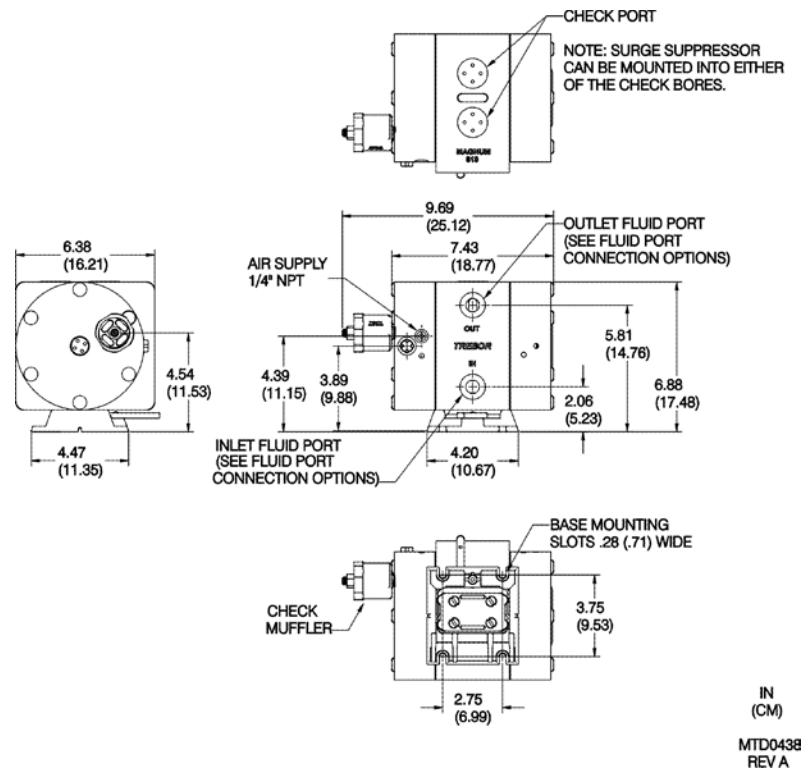

Figure 1-1

NOTE: It is recommended that a filter be placed on the discharge side of the pump.

Recommended Maximum Operating Levels: 60 psig (4.1 bar) air supply, 110°C fluid temperature (See Section 3.1 for operation at temperatures above 60°C.)

ATTENTION: The pump should be operated with clean, dry air or nitrogen. Particulate, water and oils in the air supply can damage the pump.

NOTE: Although extensive efforts are made to deliver pumps to our customers completely dry, new pumps may contain residual moisture from their final DI water test.

1.3 CHECK MUFFLER OPERATION

1.3.a Purpose

- Permits pump to operate reliably in systems that incorporate a discharge fluid “dead head” condition. (Pump air supply remains on while discharge port is closed.)
- Permits pump to operate reliably in systems that have the pump located at an elevation below the liquid supply level. (Pump air supply remains on.)

- Effectively reduces the amount of harmful acid vapors that can enter into the pump's internal air circuit components while the pump air supply is off. (A common cause of shuttle and pilot valve failures.)

1.3.b Adjustment

- The Check Muffler is preset at the factory to a setting that makes the pump "Dead Cycle" at a slow constant rate with the fluid discharge port closed, and the pump air supply at 45 psig. This setting also allows the pump to operate with approximately 4 ft. (1 meter) of H₂O positive fluid supply pressure. "Deadheading" at other air supply pressure or with more positive fluid supply pressure (fluid source above pump) may require user adjustment. The adjustment should control the pump to a slow, steady "Dead Cycle" rate with no erratic cycling/"machine gunning" evident.

NOTE: If pump application does not require operation in either of these conditions, loosen check muffler adjustment for minimum restriction.

NOTE: Air consumption during "Dead Cycling" is very little since the pump diaphragms are displacing only internal bypass. "Dead Cycling" should be considered as a standby idle mode.

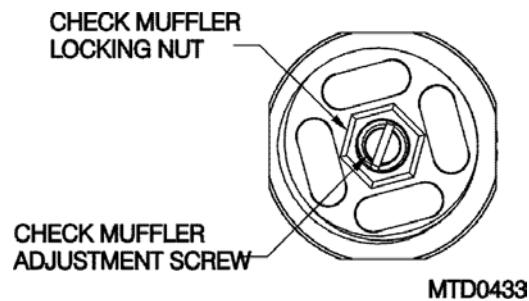

Figure 1-2

- Turn adjustment screw clockwise (CW) to increase back pressure.
- Turn adjustment screw counter-clockwise (CCW) to decrease back pressure.

NOTE: Loosen locking nut prior to making adjustment and tighten nut to maintain adjustment.

2 OPTIONS

2.1 FLUID PORT CONNECTION OPTIONS

TREBOR optional port fittings allow direct coupling of popular insert or flare tube styles as well as fuse welded pip.

NOTE: Use O-ring to seal stainless steel or other rigid plumbing.

Available Options

1/2" Flaretek (tube adapters)

3/4" Flaretek (tube adapters)

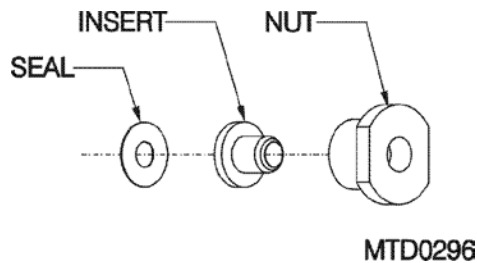

Figure 2-1

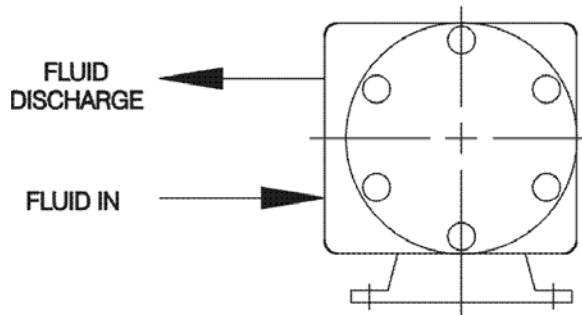

Figure 2-2: Standard Port Location

2.2 HOOK-UP WITH SURGE SUPPRESSOR

<u>Surge Suppressor</u>	<u>Assembled Height: IN (CM)</u>
SS75	12.29 (31.21)
SS85	14.82 (37.65)
SS40	12.37 (31.43)

NOTE: See Surge Suppressor Operation Manual for detailed installation instructions.

3 START-UP

- Pump air supply pressure should be regulated.
- Open the fluid suction (IN) line valve, if necessary.
- Open the fluid discharge (OUT) line valve, if necessary.
- Start with air regulator at low pressure setting. Increase or decrease pressure to attain desired flow, up to 60 psig (4.1 bar) at the pump.
- Table 1: Consumption / Efficiency can be used to determine approximate air consumption.
- Refer to Troubleshooting, Section 5, if pump fails to start.

ATTENTION: Prolonged periods (> 5 minutes) of dry running will damage critical internal pump parts.



CAUTION: When handling potentially dangerous fluids under pressure, the pump and its fittings should be placed in an enclosure.

3.1 HIGH TEMPERATURE OPERATION

Pump operation at temperatures above 60°C requires periodic tightening of the tie bolt nuts. The frequency of this procedure is best established by the user. Refer to Section 4 on Maintenance.

3.2 PERFORMANCE CHARTS

Pumping capacity is a function of air supply pressure and volume, suction head, suction line restrictions, discharge head, discharge line restriction, and fluid specific gravity and viscosity.

Air Supply Pressure (PSIG)	Discharge Fluid Pressure (PSIG)	Air Used (SCFM)	Cycles Per Minute	Displacement IN ³ Per Cycle
20	0	3.9	170	10.4
20	10	2.8	105	9.3
30	0	5.6	190	10.5
30	15	4.0	120	9.4
40	0	7.0	198	10.5
40	20	5.4	125	9.6
50	0	8.4	205	10.5
50	25	7.2	130	9.7
60	0	10.2	208	10.6
60	30	8.4	128	9.4

Table 1: Consumption / Efficiency

NOTE: Specification to be used to size regulators and control valves.

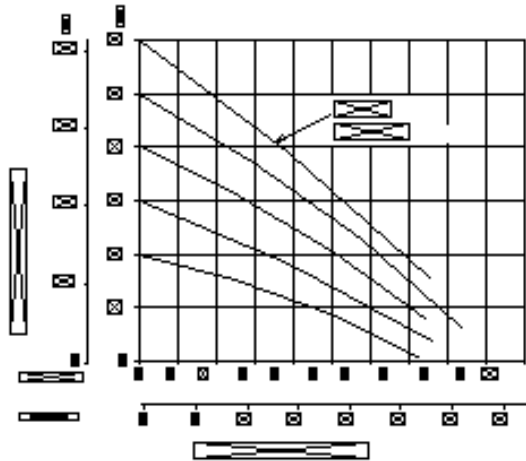

Figure 3-1: Pressure & Capacity Chart

NOTE: Test information is based on specific conditions and limited sampling. Use for general reference only. The diagram below shows the test bench layout used for ascertaining the performance information of Trebor pumps.

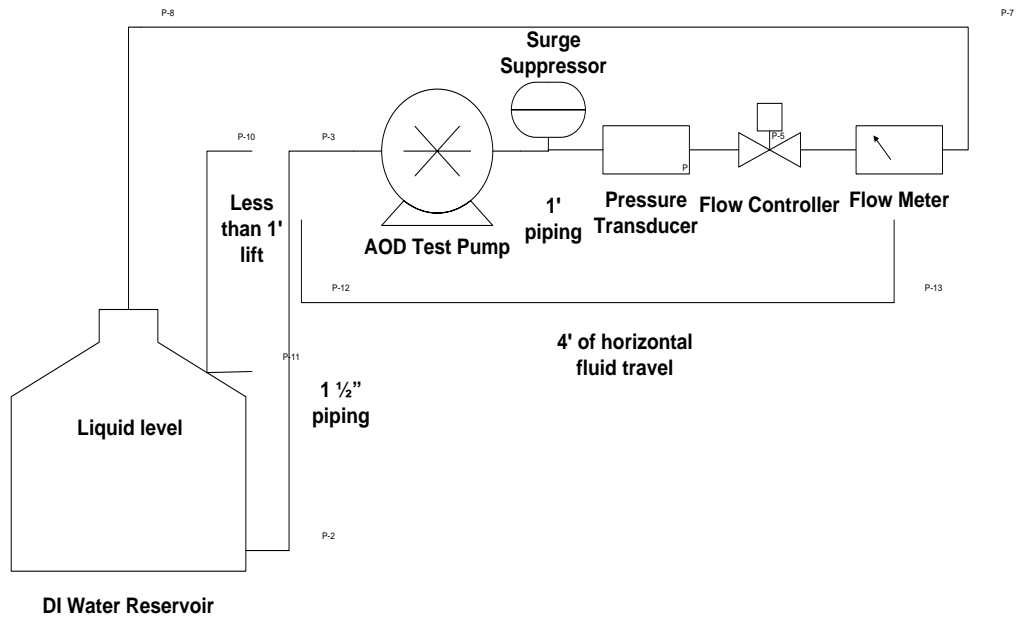

Figure 3-2

4 MAINTENANCE

Trebor pump maintenance can be divided into two categories: air system maintenance and fluid system maintenance. The purpose of air system maintenance is to prevent air system failures such as stalling or erratic cycling. The purpose of fluid system maintenance is to maintain suction and lift capabilities.

Pump Rebuild Service

Trebor International provides a factory rebuild service for customers using Trebor products. Trebor will rebuild any standard pump (exclusive of options). Please contact Trebor International Sales Department for current rebuild pricing. The fixed rebuild price includes a factory rebuild and parts equivalent to the standard rebuild kit. Each factory rebuild comes with a new one-year warranty. Repairs requiring more extensive part replacements will be quoted prior to proceeding with the pump rebuild. If the pump has exceeded its useful life and cannot be rebuilt, the customer may elect to purchase a new Trebor pump. If the customer chooses not to rebuild or replace the pump, a \$150.00 evaluation charge will be required.

All returned pumps are to be shipped freight prepaid with a valid Purchase Order for the cost of rebuild service. Please contact Trebor International prior to returning your pump to obtain an RMA Number and Pump Return Data Sheet to ensure proper safety precautions. Each pump will be evaluated and repaired within 5 working days of the receipt of pump at Trebor facility.

4.1 PREVENTIVE MAINTENANCE SCHEDULE

The following maintenance schedule is recommended to optimize pump performance and minimize failures. Tie bolt torque should be checked within 30 days of start-up and at periodic intervals thereafter. If the pump is subjected to thermal cycle operation, the tie bolt torque should be checked after the first 3 thermal cycles and periodically thereafter. Certain operating conditions that require more frequent maintenance intervals have been noted. In positive pressure inlet conditions where suction or lift is not required, fluid system maintenance may be extended. However, tie bolt retorque is still recommended.

Adhering to the recommended preventative maintenance schedule along with periodic inspection of the pump will ensure continued efficient operation and overall reliable pump performance.

It is recommended that the Preventive Maintenance Record (Section 4.1.a) be copied, maintained and kept with this unit for future reference.

Magnum 610NM Pump

Replacement			Inspection				Component / Comments
6 Month	1 Year	2 Year	3 Month	6 Month	1 Year	2 Year	
				X			Shuttle Spool, PEEK Pilots, Detent Body
	X						Detent Legs
				X			Tie Bolt Retorque (<100C)*
			X				Tie Bolt Retorque (>100C)*
		X					Check Balls and O-Rings
	X						Check Balls and O-Rings (High Suction Applications)
		X					Shaft Seal and Shaft
	X						Shaft Seal and Shaft (High Suction Applications)
	X						Diaphragms and Main Seals
X							Diaphragms and Main Seals (H _F)
X							Diaphragms and Main Seals (ACT 935 & TMAH)
		X			X		Check Muffler

* Tie bolts must be torqued on install

4.1.a Preventive Maintenance Record

Company Name: _____

Company Address: _____

Product: _____ Serial Number: _____

Date: _____ Tech: _____ Notes: _____

Date: _____ Tech: _____ Notes: _____

Date: _____ Tech: _____ Notes: _____

Date: _____ Tech: _____ Notes: _____

Date: _____ Tech: _____ Notes: _____

Date: _____ Tech: _____ Notes: _____

Date: _____ Tech: _____ Notes: _____

Date: _____ Tech: _____ Notes: _____

Date: _____ Tech: _____ Notes: _____

Date: _____ Tech: _____ Notes: _____

Date: _____ Tech: _____ Notes: _____

Date: _____ Tech: _____ Notes: _____

Date: _____ Tech: _____ Notes: _____

Date: _____ Tech: _____ Notes: _____

Date: _____ Tech: _____ Notes: _____

Date: _____ Tech: _____ Notes: _____

Date: _____ Tech: _____ Notes: _____

Date: _____ Tech: _____ Notes: _____

Date: _____ Tech: _____ Notes: _____

Date: _____ Tech: _____ Notes: _____

Date: _____ Tech: _____ Notes: _____

Date: _____ Tech: _____ Notes: _____

Date: _____ Tech: _____ Notes: _____

Date: _____ Tech: _____ Notes: _____

4.2 RECOMMENDED SPARE PARTS

KR610NM-00-D Spares Rebuild Kit, which includes:

<u>Part No</u>	<u>Qty</u>	<u>Description</u>	
KD610-00-A	1	Diaphragm Kit	
		Includes: (2) 98001422	O-Ring
		(2) C0100	Diaphragm Set
KM610NM-00-C	1	Maintenance Kit	
		Includes: (2) C0125	Detent Leg
		(1) C0127	Detent Body
11001015	1	Protective Cap Set	
1610B0022	1	Shaft	
98001415	4	Check Ball	
98001976	2	Shaft Seal	
98002331	2	O-Ring	
98002332	2	O-Ring	
98002334	4	O-Ring, PTFE	
AM084	2	Check Cap Seal	
C0135	1	Check Muffler Assembly	

4.3 TOOLS

The following tool kit is recommended as standard service equipment.

KT610NM-00-A Tool Kit, which includes:

<u>Part No</u>	<u>Qty</u>	<u>Description</u>
98001225	2	3/8" Nut Driver
98002327	1	Tool Case
98003225	1	3/8" Socket
98003305	1	1/4" Drive Handle
T000B0014	1	Check Sleeve Removal Tool
T000B0020	1	Check Sleeve Insertion Tool
T0146	1	3/4" Pin Tool
T0148	1	1/2" Pin Tool
T16002104	1	Shaft Bullet
T0144	1	Cleaning Tool

4.4 PARTS ILLUSTRATION

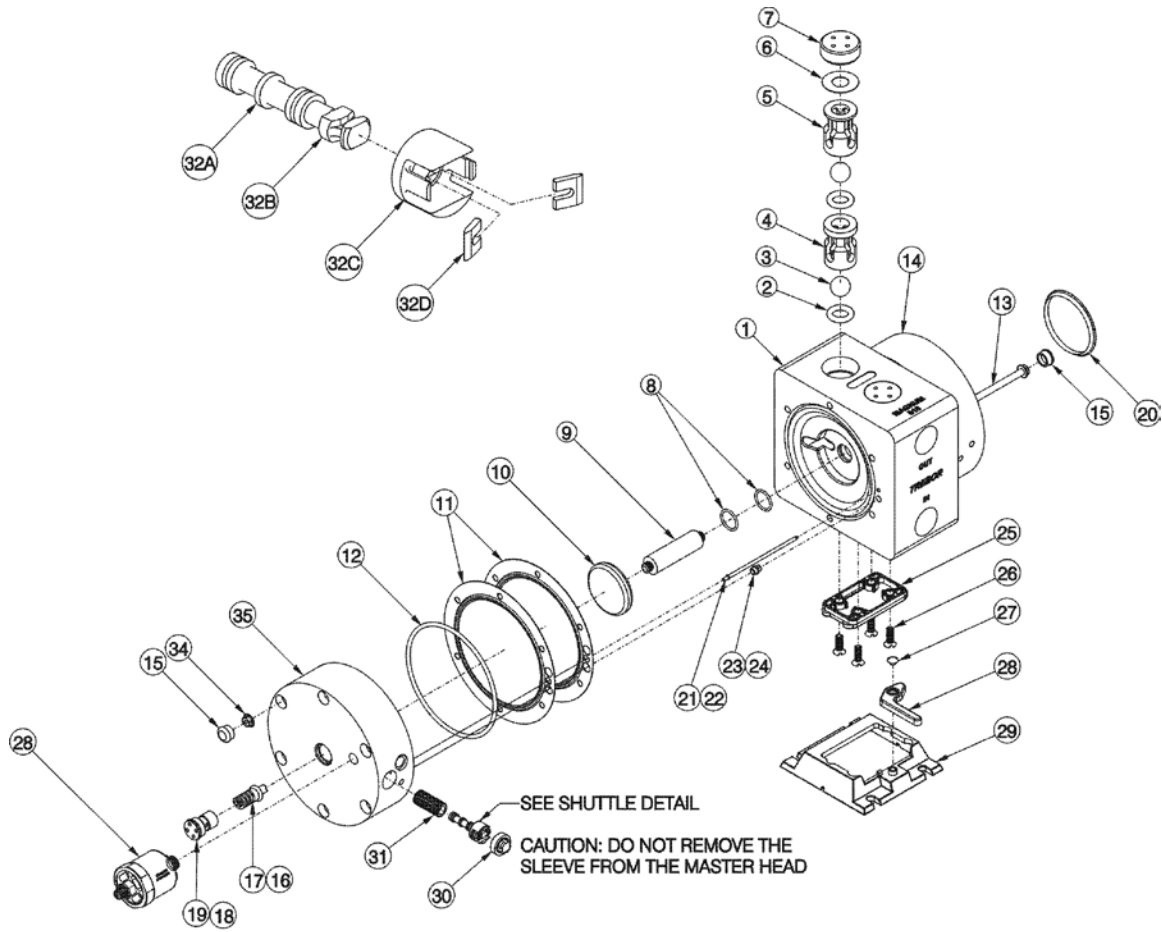

MTD0439

4.5 PARTS LIST

ILL NO	PART NO	QTY	DESCRIPTION	PM YEAR #	MATERIAL
1	C0104	1	Body		PTFE
2	98002334	4	O-Ring	2	PTFE
3	98001415	4	Check Ball	2	PTFE
4	1610B0007	2	Suction Sleeve		PTFE
5	1610B0008	2	Discharge Sleeve		PTFE
6	AM084	2	Seal	2	PTFE
7	C0133	2	Check Bore Cap		PTFE
8	98001976	2	Shaft Seal	2	PTFE
9	1610B0022	1	Shaft	2	PFA
10	C0095	2	Push Plate		PTFE
11	C0100	2	Diaphragm Set	1 & 2	PFA
12	98001422	2	Main Seal	1 & 2	Viton
13	1610B0010	6	Tie Bolt Assembly		SS416, PFA
14	C0059	1	Slave Head		PP
15	98001109	12	Tie Bolt Cap	2	PU
16	98002643	2	O-Ring		Viton
17	C0055	2	Pilot Spool		PEEK
18	C0063	2	Pilot Cap		PP
19	98002650	2	O-Ring	2	Viton
20	98002620	1	Label Cap		PE
21	98002331	2	O-Ring	2	Viton
22	1610A0013	1	Pilot Transfer Tube		PFA
23	98002332	2	O-Ring		Viton
24	1110A0022	2	Main Transfer Tube		PFA
25	AM022	1	Mounting Base		PP
26	98003207	4	Mounting Screw		PP
27	98003071	1	Screw		PP
28	AM023	1	Locking Lever		PP
29	C0102	1	Base		PP
30	C0124	1	Shuttle/Detent Cap		PP
31	C0071	1	NM Sleeve Assembly		Ceramic, Viton
32	C0128	1	Spool/Detent Assembly		Ceramic, PEEK, NYL
32a	J0064	1	Shuttle Spool		Ceramic
32b	C0126	1	Spool Head		PEEK
32c	C0127	1	Detent Body	6 mo., 1 & 2	PEEK
32d	C0125	2	Detent Leg		NYL
33	C0135	1	Check Muffler Assembly	2	PP, NPRN
34	98002338	6	Nut, Flanged		SS18-8
35	C0098	1	Master Head		PP

4.6 CLEAN-UP

To help remove potentially dangerous chemicals, the pump should be flushed with DI water or disassembled and thoroughly cleaned.

4.7 DISASSEMBLY

During the life of the pump it will be necessary to perform certain preventative maintenance procedures to ensure its continued high performance. This section and the next (4.8 Assembly) are provided for the user's convenience in disassembly and re-assembly procedures.

- Thoroughly clean / flush the pump using DI water (Refer to Section 4.6 Clean Up).
- Unlock pump from quick release base by pulling out locking lever on front of base. Then slide pump forward until it stops. Lift pump off base.

- Remove check muffler assembly.
- Remove tie bolt caps from both heads.
- Remove un-tact flanged nuts from the tie bolt assemblies (Master Head side). Using both 3/8" nut drivers. Leave tie bolts in place.
- Lay the pump on the slave head side.
- Remove the master head.
- Remove the main seal and diaphragms.
- Remove the main transfer tube and seal.
- Remove the pilot transfer tube seal.
- Remove the body assembly.
- Remove the pilot transfer tube and seal and the second main transfer tube and seal.
- Remove the slave side set of diaphragms and main seal.
- Remove tie bolts.

NOTE: All polypropylene and fluoroplastic parts, when disassembled, should be thoroughly washed and be free from acid residue for handling purposes.

4.7.a Master and Slave Heads

- Remove the shuttle cap from the master head.
- Remove the spool/detent assembly. See Section 4.4 for shuttle detail. (A small blast of air into the air inlet port will normally cause the spool/detent assembly to pop out.)

NOTE: Do not remove the shuttle sleeve from the shuttle bore.

- Remove label cap from the slave head.
- Remove the pilot caps from the master and slave heads.
- Remove pilot spools and O-rings from master and slave heads.

4.7.b Body Disassembly

- Remove check bore caps using 3/4" pin tool and remove seals.
- Remove sleeves with sleeve removal tool, check balls and O-rings.
- Unthread one push plate from the shaft.
- Remove remaining push plate and shaft from body.
- Unthread second push plate from shaft.
- Remove shaft seals from the shaft bore; taking care not to damage the shaft bore or shaft seal grooves. (Do not re-use shaft seals)

4.8 ASSEMBLY

4.8.a Head Assemblies

Pilot Valve (Both Heads)

- Install O-rings and pilot spools into head.
- Install O-rings and pilot caps.
- Install label cap on slave head.

Shuttle Assembly (Master Head)

NOTE: Ensure that the spool moves freely inside the sleeve prior to installation.

- Insert spool/detent assembly into NM sleeve assembly as shown in Figure 4-1.

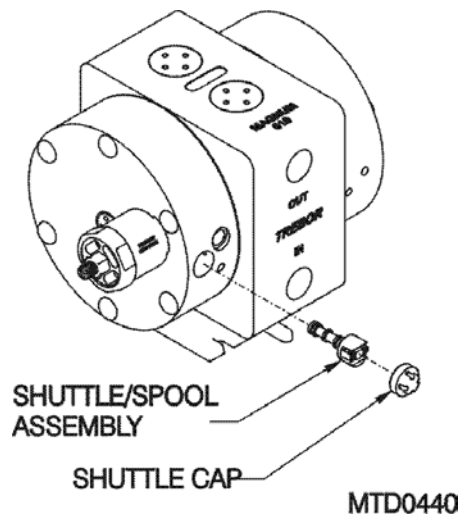
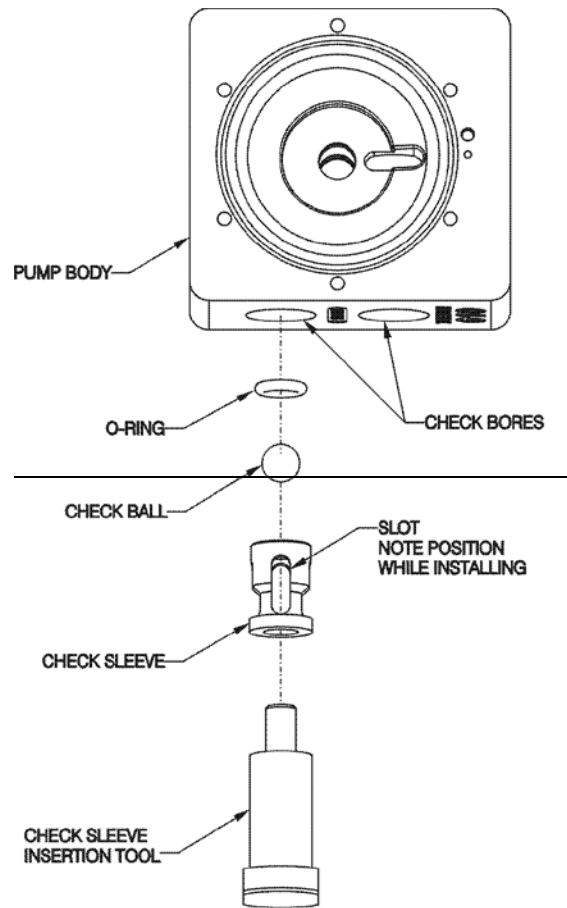

Figure 4-1

- Install shuttle cap with 2 wraps of PTFE thread tape. Trim off excess thread tape.

4.8.b Body Assembly

NOTE: For easy installation, check sleeves that fit too tightly should be placed in a freezer prior to assembly to assist insertion. Body must be upside down with check port extending over a table edge so that parts remain assembled during insertion of sleeves. (See Figure 4-2.)



MTD0321

Figure 4-2

- Insert suction sleeve, check ball and O-ring carefully into check bore.

NOTE: The Suction Sleeves have a shoulder diameter larger than their body diameter. Additionally the Suction Sleeves when compared to the Discharge Sleeves have a thicker top region which acts as a robust contact point for the O-rings.

- Repeat insertion process with the discharge sleeve, check ball and O-ring.
- Repeat process for second check bore.
- Replace check cap seals and tighten check bore caps to 50in-lbs.
- Install shaft seals into shaft bore grooves.
- Thread shaft into push plate until engagement with the shaft shoulder is achieved. Additionally apply a ¼" turn to ensure proper installation.
- Insert shaft through shaft bore using shaft bullet as shown (This prevents damage to the TFE shaft seals and prevents dislodgement of shaft seals).

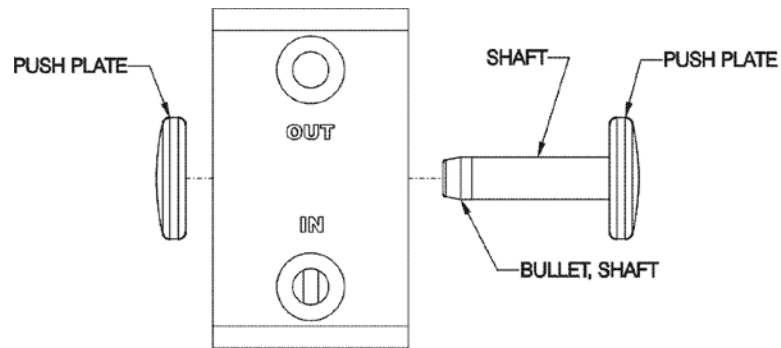

MTD0322

Figure 4-3

- Remove bullet and thread on remaining push plate, tighten per previous practice.

4.8.c Final Assembly

- Insert tie bolt assemblies through slave head and lay flat with tie bolts sticking up.
- Place main seal O-ring into the main seal groove in slave head.
- Install a diaphragm set, removing all air from between diaphragms, onto the tie bolts noting the relative orientation of the formed main seal groove in the diaphragms with respect to conforming to the main seal. Also note air transfer port hole alignment.
- Place one main transfer tube with seal into respective port.
- Place pilot transfer tube and one seal into slave head.
- Carefully place and press the body assembly onto the tie bolts, transfer tubes, seals, and slave head.
- Install the remaining diaphragm set onto the tie bolts and body, again noting formed main seal groove and transfer port seals (O-rings).
- Install O-ring onto protruding pilot transfer tube.
- Place the main seal O-ring into the formed groove of the master head.
- Place remaining main transfer tube and seal into master head.
- Lift the slave head and body, while maintaining compression of the main seal, flip the head and body over and insert the tie bolts into the master head. Ensure that the main seal of the master head is not dislodged.
- Install flange nuts onto tie bolts, tighten evenly in a star pattern (do not overload one side before applying torque to another as dislodgment of main seal can occur), final torque is 42 in-lbs.
- Install tie bolt caps and check muffler assembly.
- Install pump onto base and slide back. Use locking lever to secure.

4.9 TESTING

4.9.a Performance Test

- With the air supply at 0 psi open the air supply valve
- Increase the air pressure until the pump starts to cycle
- Record the start pressure, Target = <20psig
- Pump must prime once even cycling is achieved
- Increase pressure to 60 psi
- Check for fluid leaks, listen for air leaks, check for irregularity
- Prepare the pump for drying

4.9.b Dry Pump

- Connect vacuum hose to discharge line
- Connect purge line to fluid inlet
- 60 psig Supply Pressure
- Cycle pump & vacuum dry by rotating pump side to side for 30 seconds.
- Turn off Air Supply and allow the pump to purge for 5 minutes.

4.9.c Dry Suction

- 20 psig Supply Pressure Target
- Record Suction Value
- Target = 8 in-Hg.

5 TROUBLESHOOTING

Pump Will Not Start, Fails to Operate

Cause:

- Insufficient air pressure.
- Insufficient air volume.
- Dirty or damaged shuttle valve.
- New diaphragm installed; not stretched enough to allow contact with pilot valves.
- Both diaphragms expanded into contact with pilot valves due to excess fluid supply line pressure.
- Fluid discharge line blocked. Downstream valve closed, filter plugged or other obstruction (dead head).

Solution:

- Must be 10-15 psi greater than fluid discharge line pressure.
- See Performance Charts (Section 3.2) for requirements.
- Clean shuttle spool/detent and sleeve until free movement is assured; or replace (see 4.8.a).
- Increase air pressure up to 60 psig until pump starts. Decrease for proper flow if necessary.
- Adjust check muffler assembly (see 1.3).
- Remove obstruction. Refer to Section 1.3 for further information on “Dead Head” condition.

Bubbles in Fluid Discharge

Cause:

- Leaking fluid inlet fitting.
- Leaking main seal.
- Ruptured (perforated) diaphragm.

Solution:

- Tighten, or remove and wrap with TFE thread tape prior to tightening.
- Tighten tie bolt nuts to 42 in-lbs. Replace diaphragms if damaged.
- Replace Diaphragms.

Fluid Leaks

Cause:

- Tie bolt torque not enough to effect seal.
- Damaged main seal.
- Check bore cap.
- Ruptured diaphragm(s) can result in fluid leaks through air exhaust port and shuttle valve.

Solution:

- Tighten all nuts to 42 in-lbs.
- Replace.
Check for irregularities in diaphragm groove on pump body.
- Tighten, or remove and replace seal.
- Replace diaphragms, and any parts that may have been damaged by fluid exposure.

Erratic Cycling

Cause:

- Leaking shuttle cap.
- Fluid supply line restricted (cavitation).
- Fluid supply line pressure.
- Pilot valve not seating.
- Check ball(s) not seating.

Solution:

- Rewrap with PTFE thread tape (see 4.8.a).
- Reduce fluid restriction.
Reduce distance, height of suction head.
Increase diameter of suction supply line (reduces restriction).
- Adjust check muffler assembly (see 1.3).
- Check pilot valve function and seal.
Replace O-ring.
- Replace check balls and O-rings.

6 WARRANTY



MAGNUM 610NM PUMP

TREBOR International, Inc. warrants to the purchaser of new equipment manufactured by TREBOR to be free from defects in material and workmanship when used for its intended purpose under normal operating conditions, and maintained according to the Operation/Maintenance Manual.

TREBOR's obligation under this warranty is limited to repairing or replacing, at TREBOR's option and at the TREBOR factory, any part or parts thereof which shall, within 1 year after delivery thereof to the original purchaser, be demonstrated to TREBOR's satisfaction to have been defective. This warranty may be transferred to subsequent owners. The warranty period is based on the original ship date from the factory. All warranty related freight costs shall be borne by the customer.

Excessive wear to pump components caused by pumping abrasive solutions or chemicals, as well as damage caused by ingesting foreign objects shall not be covered by this warranty.

This warranty shall not apply to any equipment which, in the judgment of TREBOR, shall have been repaired or altered outside TREBOR's factory in any way, so as to affect its performance or reliability; subjected to misuse, negligence or accident; or used other than in accordance with TREBOR's printed instructions.

There are no terms, conditions or warranties, expressed, implied or statutory, of merchantability, fitness, capacity, or otherwise, of the goods ordered, other than, or different from, the warranty set forth above. This warranty takes precedence over any other warranty, expressed or implied.

TREBOR neither assumes, nor authorizes any other party to assume for it, any liability in connection with said equipment except as set forth above.

7 CONTACT INFORMATION

7.1 GENERAL CONTACT INFORMATION

Web: www.idex-hs.com
Phone Number: (801) 561-0303
Toll Free Number: (800) 669-1303
Fax Number: (801) 255-2312
Email: treborinfo@idexcorp.com
treborsales@idexcorp.com
Address: Trebor International
8100 South 1300 West
West Jordan, Utah 84088 U.S.A.

7.2 TECHNICAL SUPPORT

Email: treborservice@idexcorp.com
Phone Number: (801) 244-6156

7.3 REGIONAL REPRESENTATIVES

Web: www.idex-hs.com/about/distributors/trebor_distributors.aspx