

MEGA 960E PUMP

Operation / Maintenance Manual

CONTENTS

1	INSTALLATION	3
1.1	UNPACKING	3
1.2	UTILITIES / HOOK-UP	3
2	OPTIONS	5
2.1	FLUID PORT CONNECTION OPTIONS.....	5
2.2	HOOK-UP WITH SURGE SUPPRESSOR.....	5
2.3	OPTIONAL LEAK SENSING	5
2.3.a	Installation.....	5
2.3.b	Removal.....	6
2.3.c	Sensor Signal Specifications	6
3	START-UP	7
3.1	HIGH TEMPERATURE OPERATION	7
3.2	PERFORMANCE CHARTS	7
4	MAINTENANCE	9
4.1	PREVENTIVE MAINTENANCE SCHEDULE	9
4.1.a	Preventive Maintenance Record.....	11
4.2	RECOMMENDED SPARE PARTS.....	12
4.3	TOOLS.....	12
4.4	PARTS ILLUSTRATION	13
4.5	PARTS LIST	14
4.6	CLEAN-UP.....	14
4.7	DISASSEMBLY.....	14
4.7.a	Quick Exhaust/Muffler Disassembly	15
4.7.b	Body Disassembly	15
4.8	ASSEMBLY.....	15
4.8.a	Quick Exhaust (Both Heads)	15
4.8.b	Body Assembly	16
4.8.c	Final Assembly	19
4.9	TESTING	19
4.9.a	Performance Test.....	19
4.9.b	Dry Pump.....	20
4.9.c	Dry Suction	20
5	TROUBLESHOOTING	21
6	WARRANTY AND EXCLUSIONS	22
7	CONTACT INFORMATION	23
7.1	GENERAL CONTACT INFORMATION.....	23
7.2	TECHNICAL SUPPORT	23
7.3	REGIONAL REPRESENTATIVES	23

1 INSTALLATION

1.1 UNPACKING

After unpacking, the pump should be checked for any damage that may have occurred during shipment. Damage should be reported to the carrier immediately.

The following items should be included within the shipping container:

<u>Qty</u>	<u>Item</u>	<u>Description</u>
1	960E	Mega 960E Pump
1	M960E	Operation/Maintenance Manual

1.2 UTILITIES / HOOK-UP

The pump is mounted using four 1/4" bolts. It is recommended that the pump be mounted so as to deviate no more than 15° from level to maintain its self-priming ability and pumping efficiency.

Air Inlet: 3/8" NPT (3/8" Dia. [8mm] supply tube minimum).

Fluid Port

Options: See Section 2.1.

Air Supply: 25-80 psig (1.4 - 4.1 bar), clean dry air or nitrogen. (See Performance Charts, Section 3.1, for Air Consumption.)

Fluid Ports: (IN-OUT) 960E = 1 5/8-10 UNS-2B thread adapter port. (All adapter port nuts should be torqued to 55in-lbs.)

Remote

Exhaust: 3/8" NPT (3/8" Dia. minimum tube up to 6' length, 1/2" Dia. Minimum tube greater than 6' length).

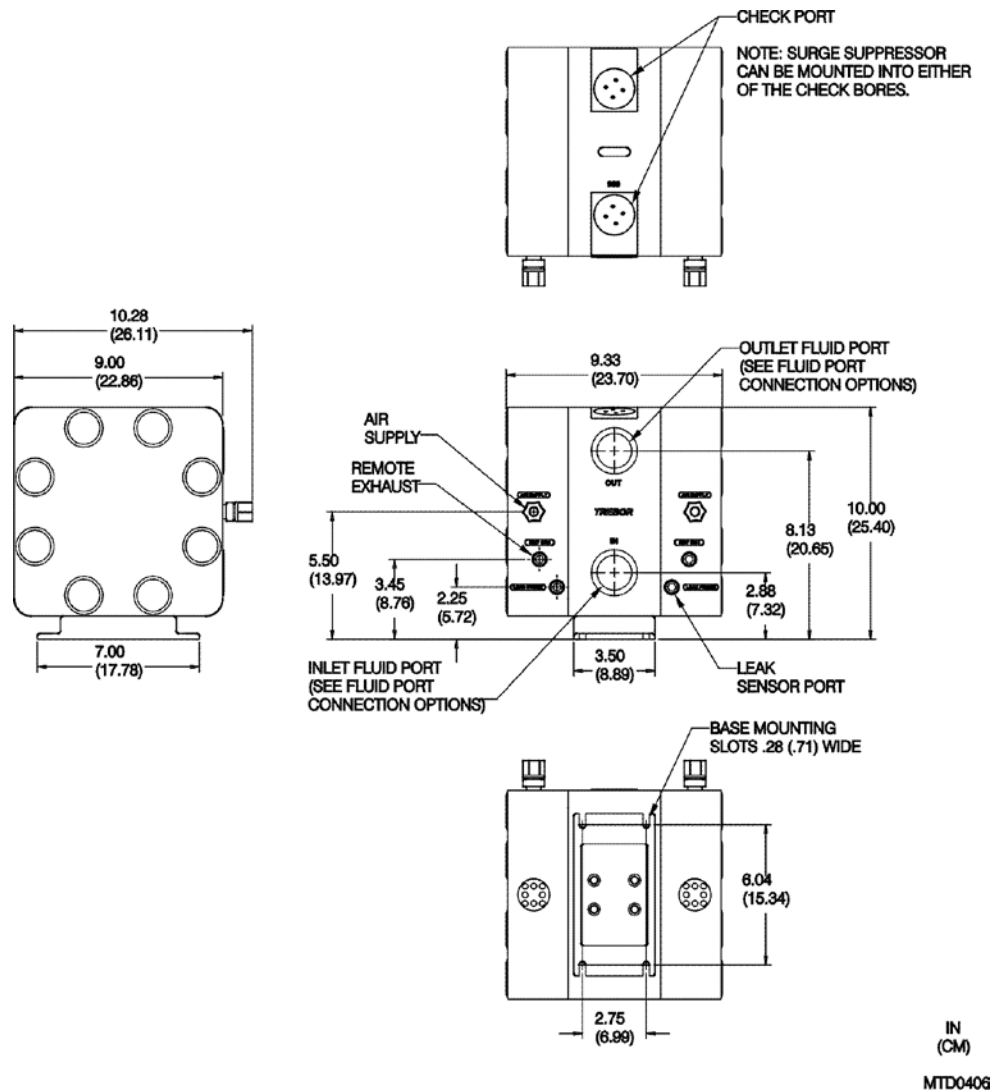

Figure 1-1

NOTE: It is recommended that a filter be placed on the discharge side of the pump.

Recommended Maximum Operating Levels: 80 psig (4.1 bar) air supply, 100°C fluid temperature

ATTENTION: The pump should be operated with clean, dry air or nitrogen. Particulate, water and oils in the air supply can damage the pump.

NOTE: Although extensive efforts are made to deliver pumps to our customers completely dry, new pumps may contain residual moisture from their final DI water test.

2 OPTIONS

2.1 FLUID PORT CONNECTION OPTIONS

NOTE: Use O-ring to seal stainless steel or other rigid plumbing.

Available Options

- 3/4" Flaretek (tube adapters)
- 1" Flaretek (tube adapters)
- 3/4" NPT (adapter nuts)
- 3/4" PFA (stubout tube)
- 1" NPT (adapter nuts)
- 3/4" PFA (pipe)
- 1" PFA (pipe)
- 1" SUPPER 300 PILLAR

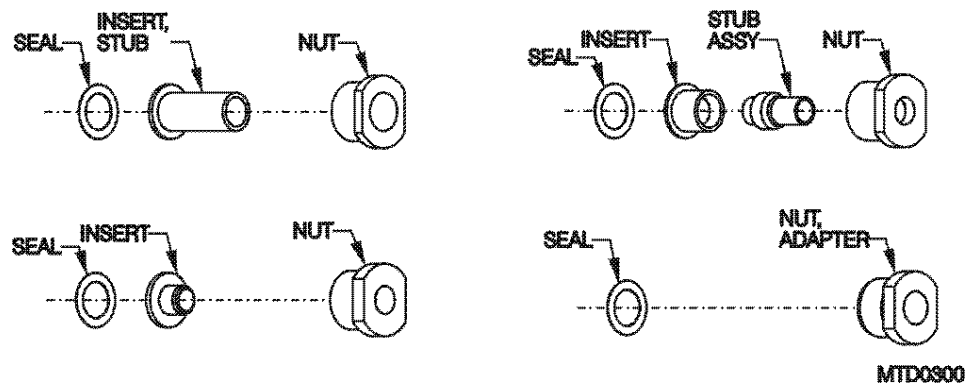

Figure 2-1

2.2 HOOK-UP WITH SURGE SUPPRESSOR

Surge Suppressor	Assembled Height: IN (CM)
MODEL 85	17.12 (43.49)
SS95	15.06 (38.25)

NOTE: See Surge Suppressor Operation Manual for detailed installation instructions.

2.3 OPTIONAL LEAK SENSING

2.3.a Installation

- Remove 3/8 NPT plug from port.
- Install 3/8 NPT leak probe fitting into port.
- Install probe assembly into fitting. Probe is self-sealing and does not require a seal.
- Tighten nut hand-tight.

- Connect fiber optic cable to sensor (NOTE: Minimize bends in fiber optic cable to 2" radius minimum to help ensure optimum signal strength.). Fiber optic cable can be cut to desired length using the cable cutter provided.

2.3.b Removal

- Remove nut from fitting.
- Remove probe.

2.3.c Sensor Signal Specifications

- The sensor signal is normally closed. In the event of a leak, no light signal is returned to the sensor.

NOTE: See your fiber optic sensor installation instructions for proper hook-up and adjustment.

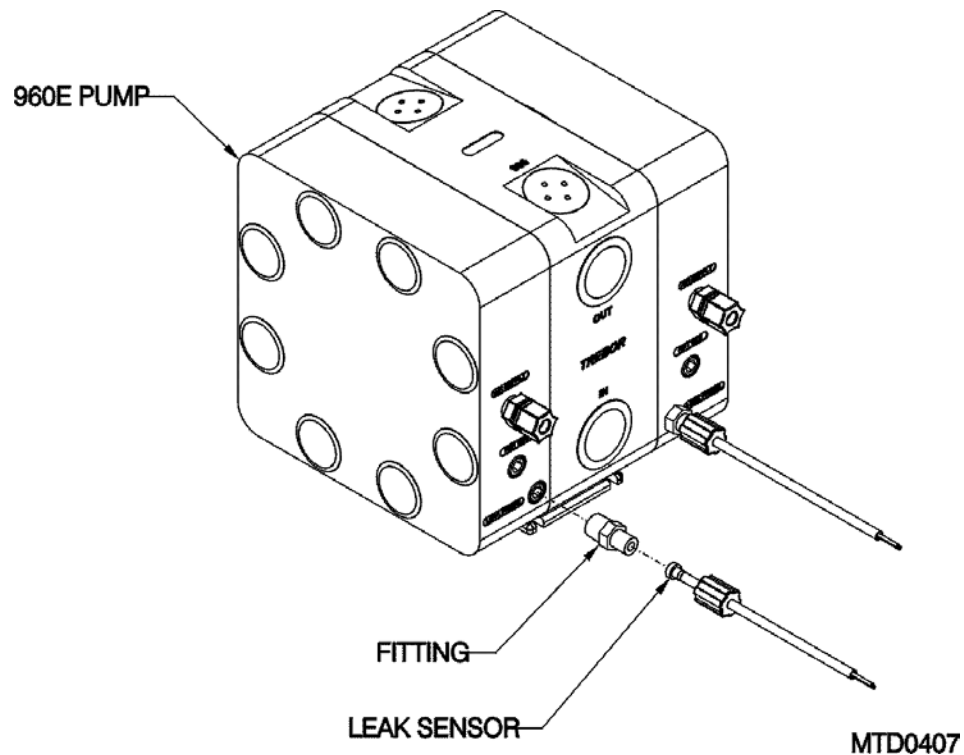

Figure 2-2

3 START-UP

- Pump air supply pressure should be regulated.
- Open the fluid suction (IN) line valve, if necessary.
- Open the fluid discharge (OUT) line valve, if necessary.
- Start with air regulator at low pressure setting. Increase or decrease air pressure to attain desired flow, up to 80 psig (4.1 bar).
- Table 1: Consumption / Efficiency can be used to determine approximate air consumption.
- Refer to Troubleshooting, Section □ if pump fails to start.

ATTENTION: Prolonged periods of dry running (>5 minutes) will damage critical internal pump parts.



CAUTION: When handling potentially dangerous fluids under pressure, the pump and its fittings should be placed in an enclosure.

3.1 HIGH TEMPERATURE OPERATION

Pump operation at temperatures above 60°C requires periodic tightening of the tie bolt nuts. The frequency of this procedure is best established by the user.

3.2 PERFORMANCE CHARTS

Pumping capacity is a function of air supply pressure and volume, suction head, suction line restrictions, discharge head, discharge line restriction, and fluid specific gravity and viscosity.

Air Supply Pressure (PSIG)	Discharge Fluid Pressure (PSIG)	Air Used (SCFM)	Cycles Per Minute	Displacement IN ³ Per Cycle (Max)
25	2	7.4	108	35
30	3	8.9	116	33
30	10	8.2	100	32
40	5	11.6	152	29
40	20	11.1	108	31
50	10	14.4	156	28
50	30	12.2	104	30
60	20	16.6	156	26
60	50	12.6	94	29

Table 1: Consumption / Efficiency

NOTE: Specification to be used to size regulators and control valves.

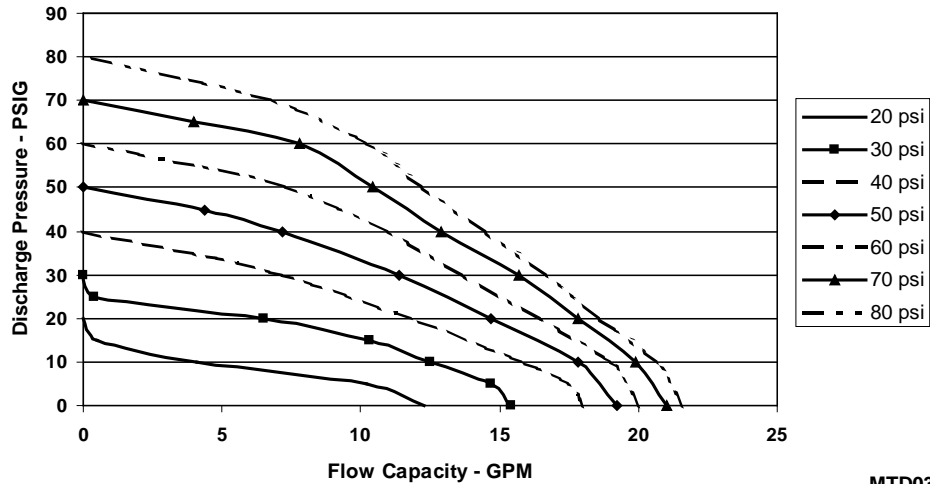

Figure 3-1: Pressure & Capacity Chart

NOTE: Test information is based on specific conditions and limited sampling. Use for general reference only. The diagram below shows the test bench layout used for ascertaining the performance information of Trebor pumps.

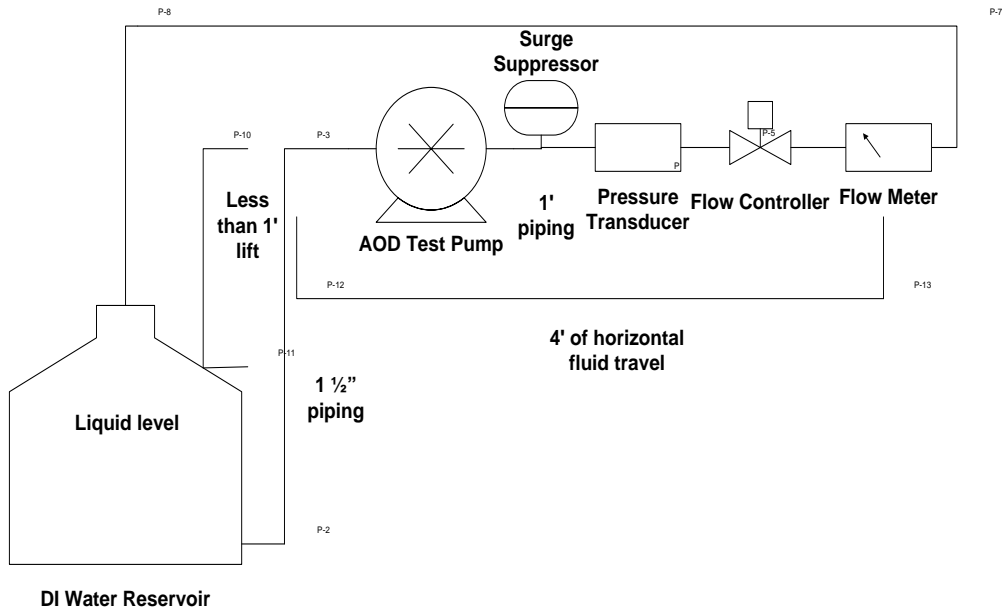

Figure 3-2

4 MAINTENANCE

Trebor pump maintenance can be divided into two categories: air system maintenance and fluid system maintenance. The purpose of air system maintenance is to prevent air system failures such as stalling or erratic cycling. The purpose of fluid system maintenance is to maintain suction and lift capabilities.

Pump Rebuild Service

Trebor International provides a factory rebuild service for customers using Trebor products. Trebor will rebuild any standard pump (exclusive of options). Please contact Trebor International Sales Department for current rebuild pricing. The fixed rebuild price includes a factory rebuild and parts equivalent to the standard rebuild kit. Each factory rebuild comes with a new one-year warranty. Repairs requiring more extensive part replacements will be quoted prior to proceeding with the pump rebuild. If the pump has exceeded its useful life and cannot be rebuilt, the customer may elect to purchase a new Trebor pump. If the customer chooses not to rebuild or replace the pump, a \$150.00 evaluation charge will be required.

All returned pumps are to be shipped freight prepaid with a valid Purchase Order for the cost of rebuild service. Please contact Trebor International prior to returning your pump to obtain an RMA Number and Pump Return Data Sheet to ensure proper safety precautions. Each pump will be evaluated and repaired within 5 working days of the receipt of pump at Trebor facility.

4.1 PREVENTIVE MAINTENANCE SCHEDULE

The following maintenance schedule is recommended to optimize pump performance and minimize failures. Tie bolt torque should be checked within 30 days of start-up and at periodic intervals thereafter. If the pump is subjected to thermal cycle operation, the tie bolt torque should be checked after the first 3 thermal cycles and periodically thereafter. Certain operating conditions that require more frequent maintenance intervals have been noted. In positive pressure inlet conditions where suction or lift is not required, fluid system maintenance may be extended. However, tie bolt retorque is still recommended.

Adhering to the recommended preventative maintenance schedule along with periodic inspection of the pump will ensure continued efficient operation and overall reliable pump performance.

It is recommended that the Preventive Maintenance Record (Section 4.1.a) be copied, maintained and kept with this unit for future reference.

Mega 960E Pump

Replacement			Inspection				Component / Comments
6 Month	1 Year	2 Year	3 Month	6 Month	1 Year	2 Year	
		X					Quick Exhaust Seal
				X			Tie Bolt Retorque*
		X					Check Balls and O-Rings
		X					Check Balls and O-Rings (High Suction Applications)
	X						Check Seat Wear Rings
	X						Shaft Bushing
		X					Shaft
	X						Shaft (High Suction Applications)
		X					Diaphragms and Main Seals
	X						Diaphragms and Main Seals (H _F)
	X						Diaphragms and Main Seals (ACT 935 & TMAH)
		X					Exhaust Muffler Media

* Tie bolts must be torqued on install

4.1.a Preventive Maintenance Record

Company Name: _____

Company Address: _____

Product: _____ Serial Number: _____

Date: _____ Tech: _____ Notes: _____

Date: _____ Tech: _____ Notes: _____

Date: _____ Tech: _____ Notes: _____

Date: _____ Tech: _____ Notes: _____

Date: _____ Tech: _____ Notes: _____

Date: _____ Tech: _____ Notes: _____

Date: _____ Tech: _____ Notes: _____

Date: _____ Tech: _____ Notes: _____

Date: _____ Tech: _____ Notes: _____

Date: _____ Tech: _____ Notes: _____

Date: _____ Tech: _____ Notes: _____

Date: _____ Tech: _____ Notes: _____

Date: _____ Tech: _____ Notes: _____

Date: _____ Tech: _____ Notes: _____

Date: _____ Tech: _____ Notes: _____

Date: _____ Tech: _____ Notes: _____

Date: _____ Tech: _____ Notes: _____

Date: _____ Tech: _____ Notes: _____

Date: _____ Tech: _____ Notes: _____

Date: _____ Tech: _____ Notes: _____

Date: _____ Tech: _____ Notes: _____

Date: _____ Tech: _____ Notes: _____

Date: _____ Tech: _____ Notes: _____

Date: _____ Tech: _____ Notes: _____

4.2 RECOMMENDED SPARE PARTS

KR960E-00-B Spares Rebuild Kit, which includes:

<u>Part No</u>	<u>Qty</u>	<u>Description</u>
KD960-00-A	1	Diaphragm Kit Includes: (2) 1900B0023 Diaphragm Set (2) 98001585 O-Ring
KM960E-00-A	1	Maintenance Kit Includes: (2) L0119 Muffler Assembly
1900A0037	2	Shaft Seal
98001108	4	Cap, Blue
98002261	4	O-Ring, PTFE
98002740	4	Check Ball
98003047	2	Seal, Quick Exhaust
L0100	16	Tie Bolt Cap
L0163	2	Check Cap Seal
L0192	1	Shaft Bushing

In critical applications, a spare pump is recommended to minimize potential down time.

4.3 TOOLS

The following tool kit is recommended as standard service equipment.

KT960-00-A Tool Kit, which includes:

<u>Part No</u>	<u>Qty</u>	<u>Description</u>
98001230	1	5/32" Allen Wrench
98002136	2	7/16" Nut Driver
98002859	1	7/16" Socket
98003150	1	Tool Case
98003305	1	Drive Handle
T000A0021	1	Shaft Bullet
T000B0007	1	Check Sleeve Insertion Tool
T000B0014	1	Check Sleeve Removal Tool
T0146	1	3/4" Pin Tool
T0147	1	1" Pin Tool
T0148	1	1/2" Pin Tool
T0159	1	2" Pin Tool
T0144	1	Cleaning Tool

4.4 PARTS ILLUSTRATION

BORDERS REPRESENT FLUID CONTACT AREAS OF PUMP

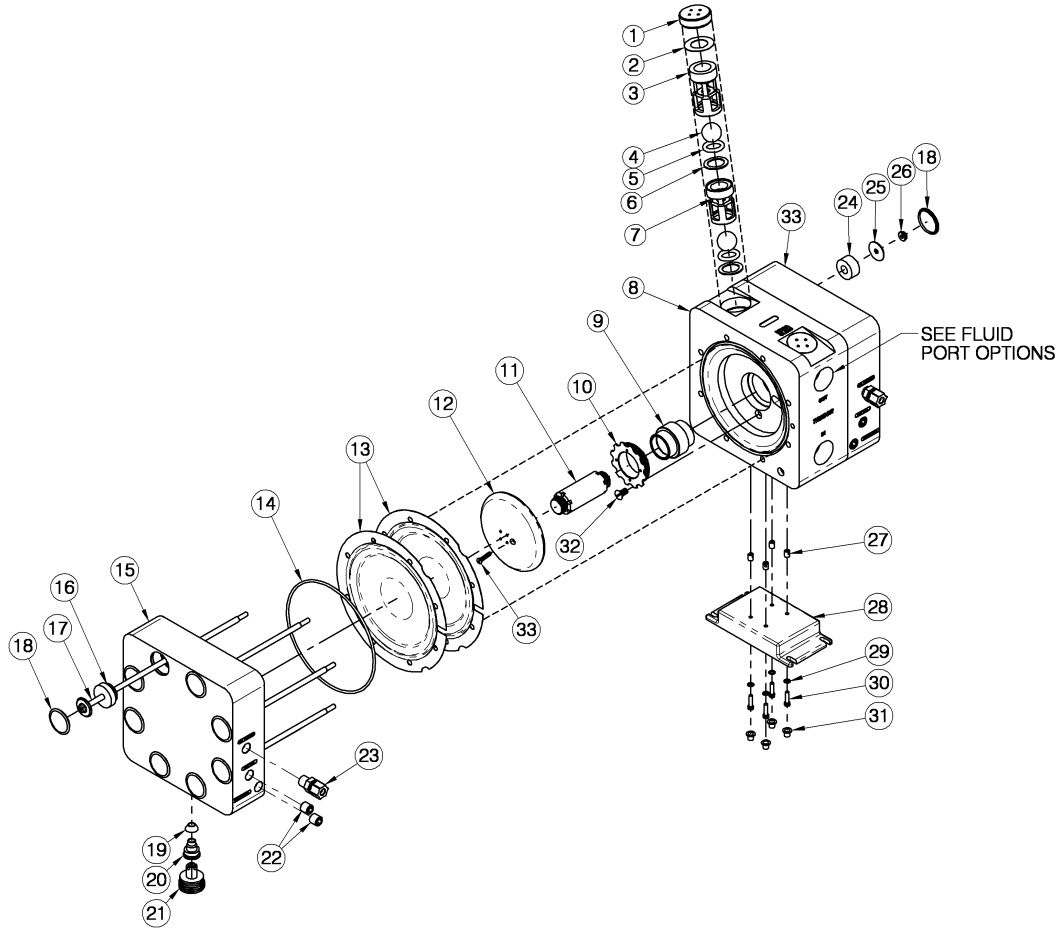

MTD0533

4.5 PARTS LIST

ILL NO	PART NO	QTY	DESCRIPTION	PM YEAR #	MATERIAL
1	L0154	2	Check Bore Cap		PTFE
2	L0163	2	Seal, Check Port	1	PTFE
3	L0096	2	Discharge Sleeve		PTFE
4	98002740	4	Check Ball	1	PTFE
5	98002261	4	O-Ring	1	PTFE
6	L0191	4	Check Seat Wear Ring		PTFE
7	L0193	2	Suction Sleeve		PTFE
8	L0190	1	Body		PTFE
9	L0192	1	Shaft Bushing	1	PTFE
10	L0195	1	Locking Ring		PTFE
11	L0123	1	Main Shaft	2	PFA
12	1900B0070	2	Push Plate		PTFE
13	1900B0023	2	Diaphragm Set	1	PFA
14	98001585	2	Main Seal	1	Viton
15	L0185	2	Head		PP
16	L0184	8	Spacer, Tie Bolt		PP
17	1900B0027-01	8	Tie Bolt Assembly		SS316, PFA
18	L0100	16	Tie Bolt Cap	1	LDPE
19	98003047	2	Quick Exhaust Seal	1	Viton
20	1900B0016	2	Quick Exhaust Port		UHMW
21	L0119	2	Assembly, Muffler	1	PP
22	98002243	10	Plug, 3/8 NPT		PE
23	98003514	2	Fitting, Air		PP
24	L0140	8	Bushing		NPRN, EPDM
25	1900A0028-01	8	Tie Bolt Washer		SS316
26	98002341	8	Nut, Flange, SS, 1/4 - 20		SS18-8
27	98001418	4	Insert		SS18-8
28	1900B0033	1	Pump Base		PP
29	98001093	4	Washer		SS18-8
30	98001375	4	Screw		SS18-8
31	98001108	4	Cap, Blue		LDPE
32	98003755	1	Screw, Lock Ring		PTFE
33	98003769	2	Screw, Push Plate		PTFE

4.6 CLEAN-UP

To help remove potentially dangerous chemicals, the pump can be flushed with DI water or disassembled and thoroughly cleaned.

4.7 DISASSEMBLY

During the life of the pump it will be necessary to perform certain preventative maintenance procedures to ensure its continued high performance. This section and the next (4.8 Assembly) are provided for the user's convenience in disassembly and re-assembly in performing these procedures.

- Thoroughly clean/flush the pump using DI water (Refer to Section 4.6 Clean-Up).
- Remove tie bolt caps from the slave head.
- Remove nuts from the tie bolts (Slave Head side). Leave tie bolts in place.
- Lay the pump on its side with slave side up.
- Lift off the slave head.
- Remove the main seal and diaphragms.

- Remove the O-rings from the shuttle transfer tube.
- Remove the body assembly.
- Remove the second set of diaphragms and main seal.
- Remove the transfer tube and O-rings from the heads and body.
- Remove the remaining tie bolt caps and tie bolts.

NOTE: All polypropylene and fluoroplastic parts, when disassembled, should be thoroughly washed and be free from chemical residue for handling purposes.

4.7.a Quick Exhaust/Muffler Disassembly

- Remove the muffler assembly from each head.
- Remove quick exhaust ports from heads.
- Remove quick exhaust seals.

4.7.b Body Disassembly

- Remove check bore caps using 3/4" pin tool and remove seals.
- Remove sleeves, balls, O-rings and check seat wear rings. Do not use excessive force.
- Unthread push plate locking screw and push plate from the one side of the shaft.
- Remove remaining shaft and push plate from body.
- Unthread second locking screw and push plate from shaft.
- Unthread shaft busing locking screw from body.
- Using 2" pin tool, insert pins in shaft bushing locking ring located in the master head side of chamber and rotate CCW to remove bushing. Then push out bushing from the slave head chamber side.

4.8 ASSEMBLY

Prior to beginning assembly, inspect all parts to ensure they are clean and dry. Wear clean protective gloves.

4.8.a Quick Exhaust (Both Heads)

- Insert quick exhaust seal.
- Insert quick exhaust port in each head as shown. Tighten to 20 in-lbs. Do not over tighten.

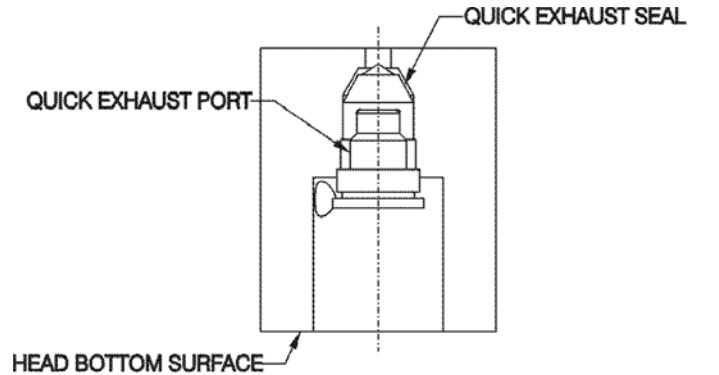

MTD0316

Figure 4-1

- Install 3 each muffler pads onto muffler spool and insert into exhaust port. Tighten to 40in-lbs

4.8.b Body Assembly

NOTE: For easy installation, check sleeves that do not install easily (minimal effort) can be placed in a freezer prior to assembly to assist insertion. Body must be upside down with check port extending over a table edge so that parts remain assembled during insertion of sleeves (See Figure 4-2.)

- Insert suction sleeve, check ball, O-ring and wear ring carefully into check bore.

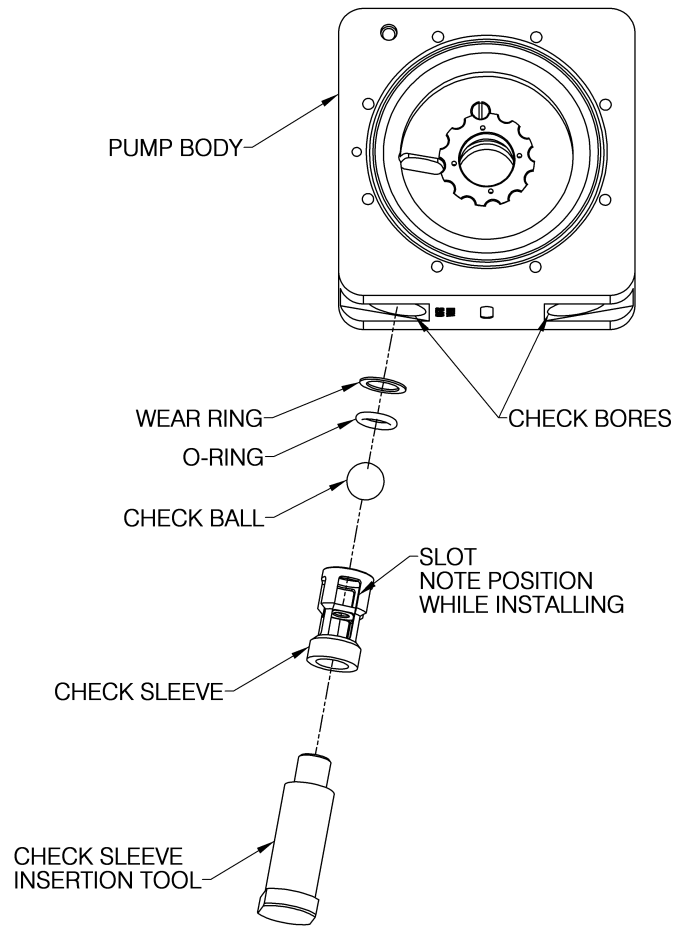

MTD0789

Figure 4-2

NOTE: The suction sleeves are 2-1/2" (6.35 cm) long. The discharge sleeves are 2.846" (7.2cm) long.

- Repeat insertion process with the discharge sleeve, check ball, O-ring and wear ring.
- Place seal and tighten check bore caps 60 in-lbs.
- Repeat process for second check bore.

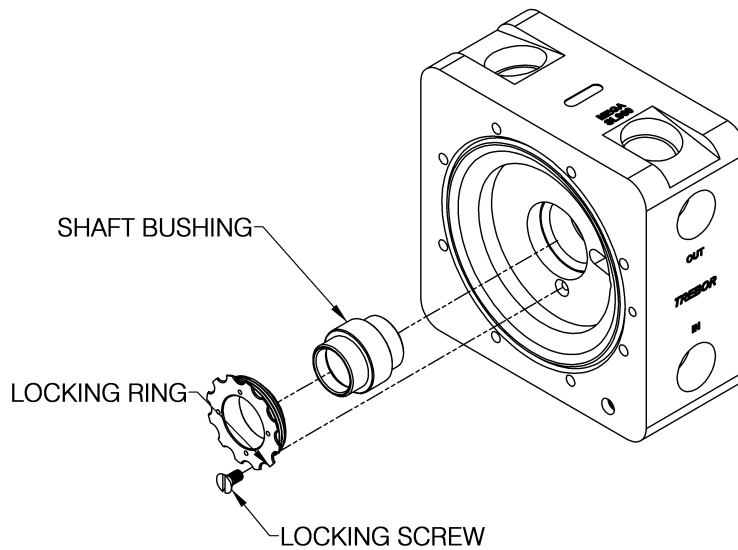

MTD0790

Figure 4-3

- Install shaft bushing per Figure 4-3.
- Install locking ring until flush with fluid cavity face and resistance is met.
- Tighten until next available notch aligns with locking screw hole, check to assure that the shaft bushing does not move.
- Insert locking screw into hole and tighten until flush with locking ring.
- Thread one push plate onto shaft until push plate bottoms out on shaft shoulder.
- Tighten push plate to 48 oz-in, and then rotate CW until locking screw hole is aligned with the next available hole in shaft. The first push plate can be visually aligned separate from the body.
- Install push plate locking screw. Tighten to 12 oz-in.

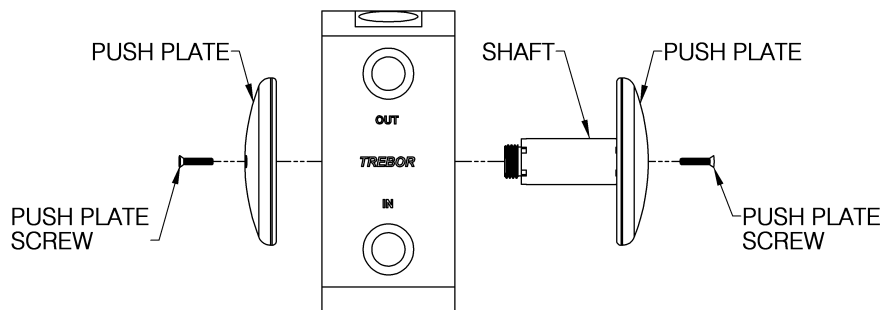

MTD0791

Figure 4-4

- Insert shaft through shaft bore as shown in figure 4-4.
- Thread on remaining push plate until push plate bottoms out on shaft shoulder.

- The second push plate, while in the pump body, can not be visually aligned. Tighten push plate to 48 oz-in, then insert alignment pin into locking screw hole. Rotate push plate CW until locking screw hole is aligned with the next available hole in shaft and alignment pin drops into the shaft hole. Remove alignment pin.
- Install push plate locking screw. Tighten to 12 oz-in.

4.8.c Final Assembly

(See Section 4.4, Parts Illustration, for reference.)

- Insert tie bolts into master head (press fit) and lay head flat with tie bolts sticking up.
- Insert main transfer tube and O-ring into head.
- Install shuttle transfer tube with two O-rings.
- Place main seal into the main seal groove in master head.
- Install two diaphragms, removing all air from between diaphragms, onto the tie bolts and shuttle transfer tube. Note main seal groove alignment.
- Place body assembly onto tie bolts and master head, ensuring alignment of shuttle transfer tube and its corresponding body passage hole.
- Place remaining two diaphragms onto tie bolts, body and shuttle transfer tube. Note main seal groove alignment.
- Place two O-rings onto shuttle transfer tube.
- Place the main seal O-ring into the formed groove of the slave head.
- Place a second main transfer tube and O-ring into slave head.
- Lift the slave head and body, while maintaining compression of the main seal, flip the head and body over and insert the tie bolts into the master head. Ensure that the main seal of the master head is not dislodged.
- Place all bushings & flat washers onto tie bolt threaded ends.
- Install flange nuts onto tie bolts, tighten evenly in a star pattern (do not overload one side before applying torque to another as dislodgment of main seal can occur), final torque is 60 in-lbs.
- Snap in tie bolt caps.

4.9 TESTING

4.9.a Performance Test

- Start with air regulator at low (< 15 psi) pressure setting.
- Pump must prime once pressure is increased
- 60 psig Supply Pressure
- Check for fluid leaks, listen for air leaks, check for irregularity
- Prepare the pump for drying

4.9.b Dry Pump

- Connect vacuum hose to discharge line
- Connect purge line to fluid inlet
- 60 psig Supply Pressure
- Cycle pump & vacuum dry by rotating pump side to side for 30 seconds.
- Turn off Air Supply and allow the pump to purge for 5 minutes.

4.9.c Dry Suction

- 20 psig Supply Pressure Target
- Record Suction Value
- Target = 14in-Hg

5 TROUBLESHOOTING

Pump Will Not Start, Fails to Operate

Cause:

Insufficient air volume.

Fluid discharge line blocked.
Downstream valve closed, filter plugged
or other obstruction.

Solution:

See Performance Charts (3.1) for requirements.
Reference regulator and control valve capacity
specifications >1.2 Cv.

Remove obstruction.

Bubbles in Fluid Discharge

Cause:

Leaking fluid inlet fitting.

Leaking main seal.

Pump inlet line pressure reached
saturation point (due to high suction
requirement).

Ruptured (perforated) diaphragm.

Solution:

Tighten, or remove and wrap with TFE thread tape prior to
tightening. Replace adapter O-ring.

Tighten tie bolt nuts to 60 in-lbs. Replace main seals if
damaged.

Increase diameter of suction supply line (reduces
restriction).

Reduce output flow.

Replace diaphragms.

Fluid Leaks

Cause:

Tie bolt torque not enough to effect
seal.

Damaged main seal.

Check bore cap.

Ruptured diaphragm(s) can result in
fluid leaks through air exhaust port.

Solution:

Tighten all nuts to 60 in-lbs.

Replace.

Check for irregularities in diaphragm groove on pump
body.

Tighten, or remove and replace seal.

Replace diaphragms, and any parts that may have been
damaged by fluid exposure.

Reduced Performance

Cause:

Supply line restricted (cavitation).

Quick exhaust seal not seating.

Check ball(s) not seating.

Solution:

Reduce fluid restriction.

Check for particles between seal and port. Replace seal.

Check O-rings for damage; replace if necessary.

Make sure check balls move freely in sleeves.

6 WARRANTY AND EXCLUSIONS

See the Trebor Standard Limited Warranty at: www.idex-hs.com/support/trebor/downloads/TreborStandardLimitedWarranty_02-07.pdf

7 CONTACT INFORMATION

7.1 GENERAL CONTACT INFORMATION

Web: www.idex-hs.com
Phone Number: (801) 561-0303
Toll Free Number: (800) 669-1303
Fax Number: (801) 255-2312
Email: treborinfo@idexcorp.com
treborsales@idexcorp.com
Address: Trebor International
8100 South 1300 West
West Jordan, Utah 84088 U.S.A.

7.2 TECHNICAL SUPPORT

Email: treborservice@idexcorp.com
Phone Number: (801) 244-6156

7.3 REGIONAL REPRESENTATIVES

Web: www.idex-hs.com/about/distributors/trebor_distributors.aspx