

# ***IQ CHEMICAL HEATER***

---

## ***Operation / Maintenance Manual***

**SERIAL NUMBER:**

**PATENTS: U.S. 5971402, U.S. 6433319, U.S. 6479094B2, U.S. 6544583B2,  
U.S. 6580061B2, U.S. 6663914, U.S. 6674053B2;  
ADDITIONAL PATENTS PENDING**

---

# CONTENTS

---

<b>1</b>	<b>INTRODUCTION.....</b>	<b>3</b>
1.1	INTENDED USE AND AUDIENCE.....	4
<b>2</b>	<b>SAFETY .....</b>	<b>5</b>
2.1	SAFETY PRECAUTIONS.....	5
2.1.a	General Safety.....	5
2.2	SAFETY MESSAGE CONVENTIONS.....	5
2.2.a	Caution .....	5
2.2.b	Warning .....	6
2.2.c	Danger.....	6
2.3	HEATER INTERLOCKS .....	6
2.3.a	Leak Sensor.....	6
2.3.b	Element Over-Temperature Protection.....	7
2.3.c	Liquid Over-Temperature Protection .....	8
2.3.d	Liquid Level Sensor Interlock.....	8
<b>3</b>	<b>INSTALLATION .....</b>	<b>9</b>
3.1	UTILITY REQUIREMENTS .....	10
3.2	UNPACKING .....	10
3.3	ORIENTATION .....	10
3.4	FLUID CONNECTIONS.....	10
3.4.a	Inlet & Outlet.....	10
3.4.b	Liquid Drain.....	11
3.5	ELECTRICAL CONNECTIONS.....	11
<b>4</b>	<b>OPERATION.....</b>	<b>12</b>
4.1	GENERAL.....	12
4.2	LIQUID START-UP.....	12
4.3	TEMPERATURE CONTROL.....	13
4.4	SHUT DOWN .....	13
<b>5</b>	<b>MAINTENANCE.....</b>	<b>14</b>
5.1	SPARE PARTS.....	14
5.2	PREVENTIVE MAINTENANCE SCHEDULE .....	14
5.3	REMOVAL AND REPLACEMENT INSTRUCTIONS .....	14
5.3.a	Heater Replacement.....	14
5.3.b	Heater Decommissioning.....	14
5.3.c	Heater Disposal .....	14
<b>6</b>	<b>TROUBLESHOOTING .....</b>	<b>15</b>
6.1	IRREGULAR TEMPERATURE CONTROL.....	15
6.2	HEATER ELEMENT CHECK.....	15
6.3	INTERLOCK SENSORS.....	16
<b>7</b>	<b>WIRING SCHEMATIC .....</b>	<b>17</b>
<b>8</b>	<b>OPTIONS .....</b>	<b>19</b>
8.1	FLUID CONNECTIONS.....	19
8.2	LIQUID LEVEL SENSOR .....	19
8.3	INTERLOCK TEMPERATURE SENSORS .....	19
<b>9</b>	<b>WARRANTY AND EXCLUSIONS .....</b>	<b>20</b>
<b>10</b>	<b>CONTACT INFORMATION .....</b>	<b>21</b>
10.1	GENERAL CONTACT INFORMATION.....	21
10.2	TECHNICAL SUPPORT .....	21
10.3	REGIONAL REPRESENTATIVES .....	21

# 1 INTRODUCTION

## **IQ Chemical Heater - The Smart Choice!**

Trebor's IQ in-line quartz chemical heater provides the ultra-high purity you demand, with the reliability you expect.

The IQ's flow path is smooth, free of particle traps and constructed entirely of GE 214 quartz and PFA, making it compatible with all non-combustible chemistries, except HF & KOH. The PFA enclosure ensures plenum compatibility and resists corrosion or discoloration. Most importantly, unlike immersion style resistive heaters your application is free from metal ion contamination risk if the external thin-film heating element should fail.

Trebor's patented sealing technology not only protects against liquid leaks, but eliminates the breakage commonly associated with fragile quartz fluid connections. Plus, there are no O-rings to service or replace.

Simplicity and flexibility are key elements of the IQ heater. The modular design allows heaters to be connected in parallel or series. Heaters are available in multiple voltages and with multiple fluid fitting options to accommodate your heating needs.

### **Features**

- Quartz/PFA liquid path
- Multiple fluid fitting options
- No metal contamination risk
- No particle traps
- Efficient heat transfer and small thermal volume for fast response
- SEMI S2, S3, UL and CE certified (pending)

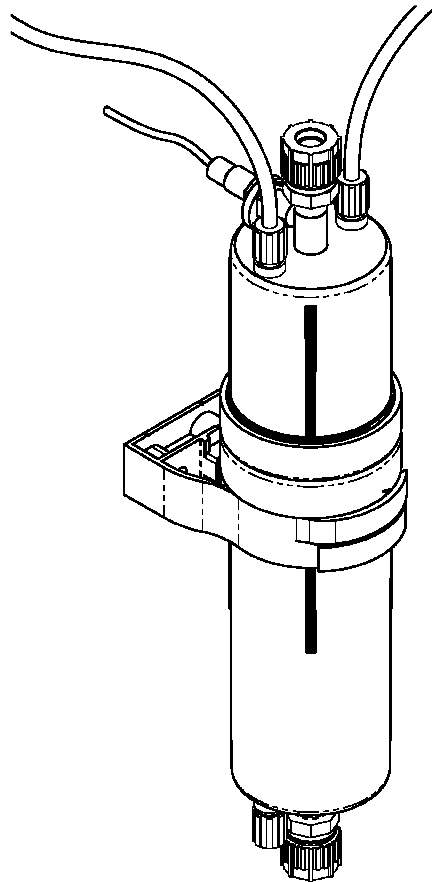

**Shown with Optional Capacitive Fluid Sensor and Pillar Super 300 Fluid Connections and Drain**

## 1.1 INTENDED USE AND AUDIENCE

The IQ chemical heater is designed to safely heat acids, DI water, and other noncombustible quartz-compatible liquid solutions up to 200°C. The IQ chemical heater is not intended for use with combustible or flammable chemistries, such as solvents, or chemistries such as HF or KOH with accelerated quartz etch rates.

This manual only covers the Trebor IQ chemical heater and heater accessories provided by Trebor. The user is responsible for the external control system and all necessary connections required to safely operate the heater (see Sections 4.3 and 7)

The Trebor IQ chemical heater is not to be used for purposes other than that which is designed for. The heater and optional components are to be used only with liquids and parameters stated within this manual. This manual assumes personnel are familiar with the installation, operation and maintenance requirements of chemical heaters.

The IQ chemical heater is intended for use by properly trained personnel. Read and understand this manual prior to installation and/or operation of the heater. Do not use this equipment until familiar with its operation and safety features.

---

## 2 SAFTEY

---

### 2.1 SAFETY PRECAUTIONS

This section provides important information for safe operation of the IQ chemical heater.

The equipment described in this manual uses hazardous voltage electricity that can be dangerous. Local policies and procedures for safely operating any Trebor chemical heater(s) supersede the safety considerations listed below. It is the responsibility of all personnel to follow such policies and procedures. All safety guard devices must be in place when equipment is in operation. Operators, set-up operators, helpers or installation personnel should not alter, remove or disable safety devices or equipment.

#### 2.1.a General Safety

- There are no serviceable parts inside the heater assembly; never open or disassemble. Attempting to do so will void the product warranty.
- Do not attempt to work on or with hazardous chemicals or electrical equipment without proper safety training and certification, understand first aid for electrical shock and hazardous chemicals spills.
- Lockout and tag the electrical and chemical systems prior to installation or replacement. Refer to company safety policies and procedures prior to installation or replacement.
- Always disengage the heater and optional equipment from electrical sources prior to installation or replacement.
- Always refer to company safety policies and procedures for flushing and decontamination prior to removal.

### 2.2 SAFETY MESSAGE CONVENTIONS

#### 2.2.a Caution

A Caution message indicates a potentially hazardous situation, which, if not avoided, could result in minor or moderate injury. It may also be used to alert against unsafe practices. A typical **Caution** message:

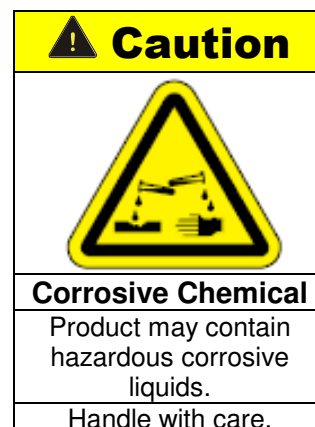

### 2.2.b Warning

A Warning message indicates a potentially hazardous situation that, if not avoided, could result in serious injury. A typical example of a **Warning** message:

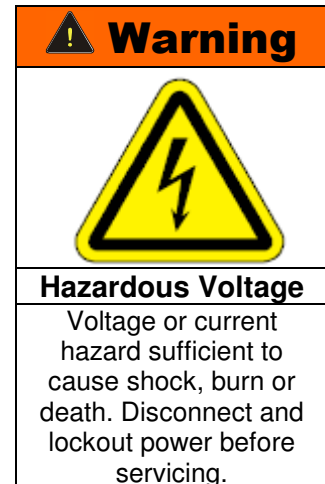

### 2.2.c Danger

A Danger message indicates an imminently hazardous situation that, if not avoided, will result in death or serious injury. Messages identified by the word **Danger** are used sparingly and only for those situations presenting the most serious hazards

## 2.3 HEATER INTERLOCKS

### 2.3.a Leak Sensor

The Trebor IQ chemical heater is supplied with a 24Vdc conductive liquid leak sensor. Note, two modes of operation are available – NPN (normally open) and PNP (normally closed).

An integrated magnetic reed switch allows a non-intrusive method for verification of sensor operation. Pass a magnet next to the area near the heater bottom, labeled "LEAK SEASOR TEST" to engage the reed switch and alarm the leak sensor, see Figure 2-1. See Section 7 for wiring instructions.

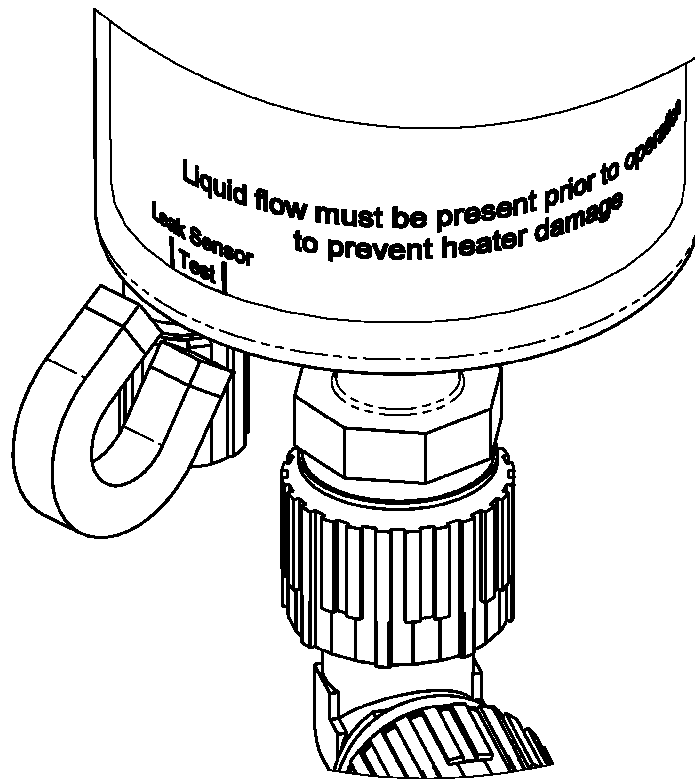

Figure 2-1

Note: The heater has no provision for monitoring or controlling flow rates or provisions to turn off flow to the heater during a leak alarm. It is recommended that the user incorporate a separate interlock to isolate flow and power from the heater in the event of an alarm.

### 2.3.b Element Over-Temperature Protection

The Trebor IQ chemical heater is supplied with a temperature sensor(s) located on the heater element. The element temperature sensor(s) must be used with an interlock to ensure the element temperature does not exceed 250 °C. Note, two types of sensors are available – thermocouple and RTD. See Section 7 for wiring instructions.

### 2.3.c Liquid Over-Temperature Protection

The maximum liquid temperature ( $T_{\max}$  °C) can be estimated from the element temperature ( $T_e$  °C), heater power rating ( $P$  - i.e. 3-kW, 4-kW, 6-kW, etc.) and duty cycle (duty %).  $T_e = T_{\max} + P * \text{duty} * 16.1$

**Example 1:** Given a maximum allowable liquid temperature of 140 °C, a heater rated at 6 kW and a 100% duty cycle, the maximum element temperature limit is:

$$T_e = 140^{\circ}\text{C} + (6) * (1.00) * (16.1)$$

$$T_e = 236.6^{\circ}\text{C} \text{ (Maximum allowable element temperature)}$$

**Example 2:** Given a maximum allowable liquid temperature of 140°C, a heater rated at 6 kW and a 75% duty cycle, the maximum element temperature limit is:

$$T_e = 140^{\circ}\text{C} + (6) * (0.75) * (16.1)$$

$$T_e = 212.5^{\circ}\text{C} \text{ (Maximum allowable element temperature)}$$

### 2.3.d Internal Over-Temperature Protection

The Trebor IQ chemical heater is supplied with a temperature sensor(s) located near the top of the quartz substrate. The control system must limit the quartz substrate temperature interlock sensor to a maximum temperature of 200°C. Note, two types of sensors are available – thermocouple and RTD. See Section 7 for wiring instructions.

### 2.3.e Liquid Level Sensor Interlock

The Trebor IQ chemical heater requires a liquid level interlock with a sensor located at the heater outlet to prevent dry operation, see Figure 2-2 for example. See Section 7 for wiring instructions for Trebor's optional liquid level sensor.

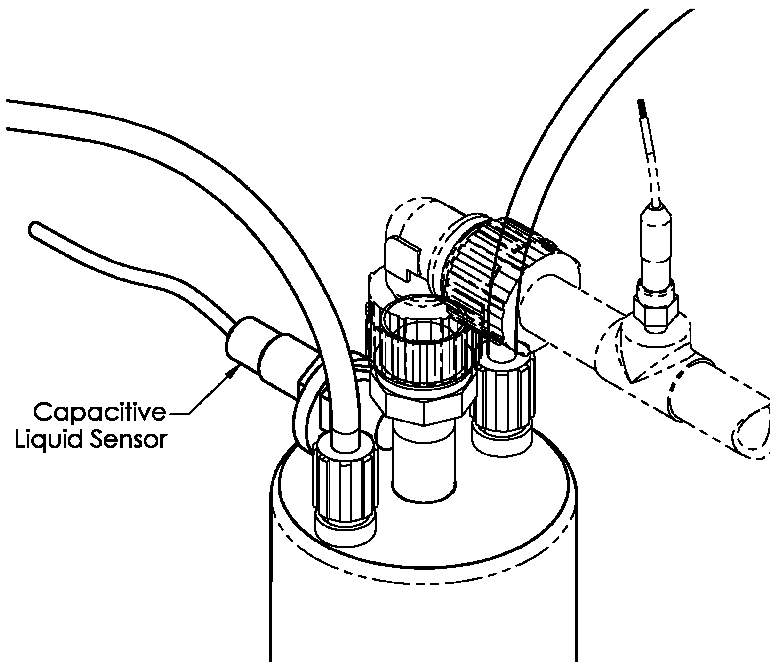
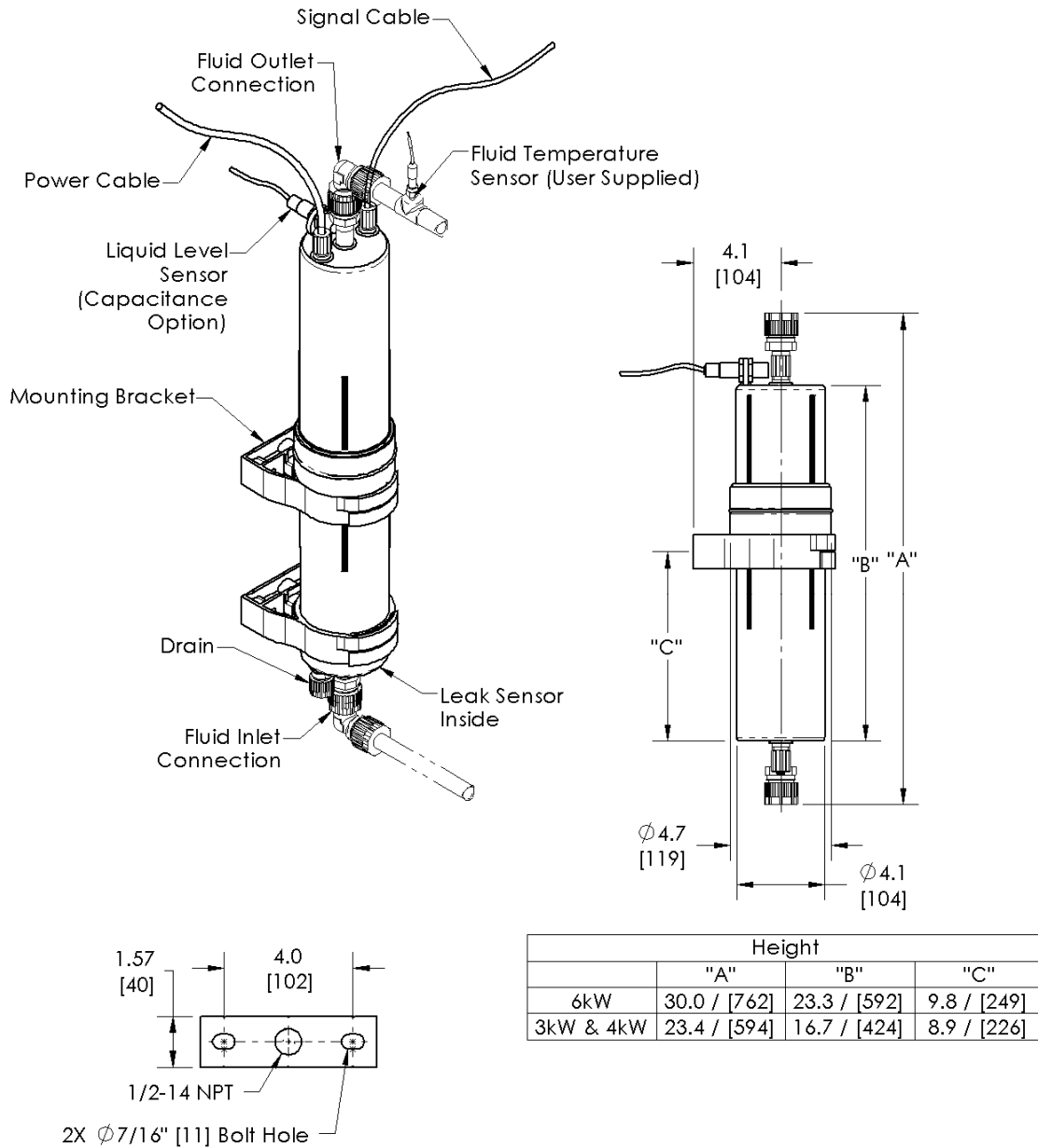

Figure 2-2

### 3 INSTALLATION

Ensure that all heater interlock and safety devices are functional prior to operation (refer to Section 2, Safety Requirements). Before starting the system, it is important to read and understand Section 4, Operation. Only trained, qualified, authorized personnel should operate this heater.



#### Mounting Bracket

Figure 3-1

### 3.1 UTILITY REQUIREMENTS

<u>Utility</u>	<u>CHEMICAL Heater</u>
<b>System Power:</b>	<ul style="list-style-type: none"> <li>• 3kW 208 Vac 50/60 Hz, 1Ø, 20 Amp Service</li> <li>• 4kW 208 Vac 50/60 Hz, 1Ø, 25 Amp Service</li> <li>• 6kW 400 Vac 50/60 Hz, 1Ø, 20 Amp Service</li> <li>• 3kW 400 Vac 50/60 Hz, 3Ø, 20 Amp Service</li> <li>• 4kW 400 Vac 50/60 Hz, 3Ø, 25 Amp Service</li> <li>• 6kW 400 Vac 50/60 Hz, 3Ø, 30 Amp Service</li> </ul>
<b>Maximum Pressure</b>	.55 MPa (80 psig)
<b>Heater Weight:</b> (Approximate)	<ul style="list-style-type: none"> <li>• 3 &amp; 4 kW – 2.2 Kg (4.9 lbs.) dry</li> <li>• 6 kW – 3.4 Kg (7.6 lbs.) dry</li> </ul>

### 3.2 UNPACKING

The system should be checked for any damage that may have occurred during shipment. Damage should be reported to the carrier immediately.

The following items should be contained within the shipping container:

<u>QTY.</u>	<u>DESCRIPTION</u>
1	Chemical Heater / Optional Accessories
1	Operation / Maintenance Manual

### 3.3 ORIENTATION

The heater must be positioned within 15° of vertical. Horizontal mounting will reduce heater life and void warranty. The heater should be installed so that the weight of the heater is either supported by the heater mounting bracket or other system that prevents the support of the heater on the plumbing.

### 3.4 FLUID CONNECTIONS

#### 3.4.a Inlet & Outlet

- Attach the inlet and outlet fluid connections following the fitting manufacturer's procedures. Fluid connections are located at the bottom (inlet) and top (outlet) of the heater, see Figure 3-1.
- Verify flow direction.
- TREBOR recommends operating the heater with DI water for two or more thermal cycles to visually inspect for leaks prior to heating chemicals.

### **3.4.b Liquid Drain**

- A liquid drain port is located at the bottom of the heater to drain off any liquid that may be present inside the housing, see Figure 3-1.

## **3.5 ELECTRICAL CONNECTIONS**

Connection of required electrical hook-ups is required between the heater and control system. See Section 7 for wiring instructions.

## 4 OPERATION

### 4.1 GENERAL

Ensure that all heater interlock and safety devices are functional prior to operation (refer to Section 2, Safety Requirements).

The IQ chemical heater is designed to heat liquid chemicals in either single pass (trim) or recirculation applications up to 200 °C (100 °C max for IQL configuration). Figure 4-1 shows flow capacity versus temperature rise per fluid pass.

**⚠ WARNING:** Heater is capable of supplying liquids beyond 200 °C. Safety precautions should be taken (refer to Section 2, Safety Requirements).

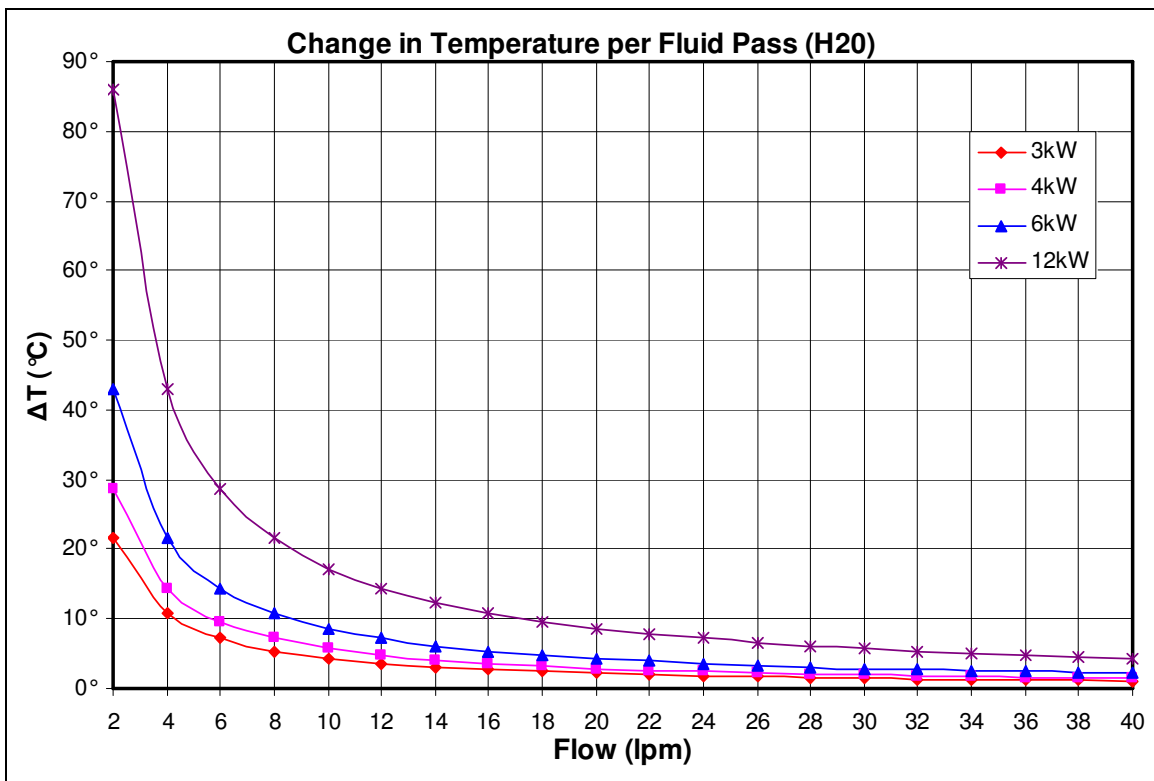

Figure 4-1

### 4.2 LIQUID START-UP

- Ensure that plumbing is secure.
- Turn “On” the liquid supply.
- Check for leaks in the system plumbing.

- Allow the liquid to run through the system approximately 2 minutes prior to energizing the heater.

### 4.3 TEMPERATURE CONTROL

An external control system is required for operating the IQ chemical heater; see Figure 4-2 for a typical control set up. The system should consist of: temperature control system, interlock controls (see Section 2.3), and outlet liquid temperature sensor(s). Operating settings and parameters are to be determined by the user.

The control scheme should be set up to not only control the liquid outlet temperature but also limit the heater element surface temperature to a maximum of 250 °C (see Section 2.3.b).

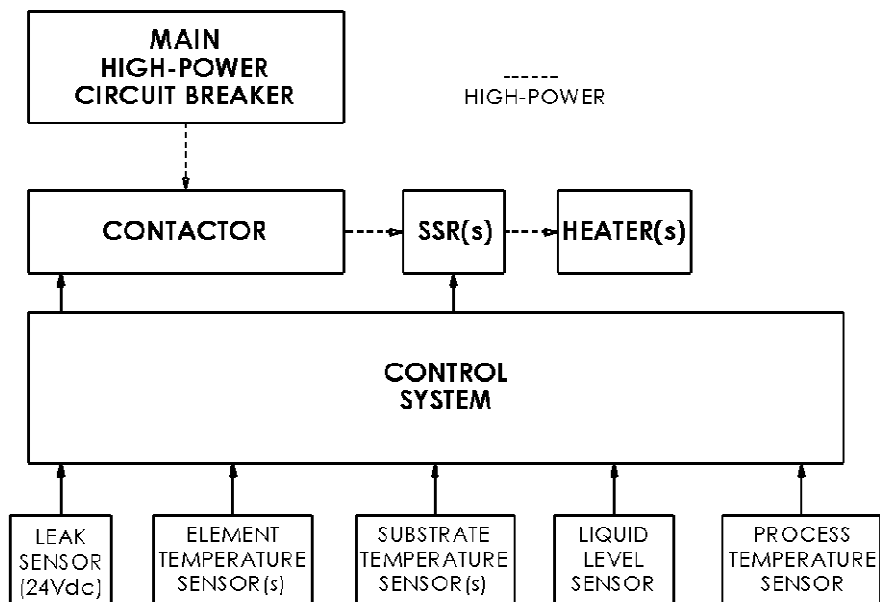

Figure 4-2

### 4.4 SHUT DOWN

The following procedure should be used to safely shut down the heater:

- Cut-off power to the heater.
- Allow liquid to pass through the heater for at least 5 minutes or until the outlet temperature drops below 50 °C.

Note: The user is responsible for providing an EMO circuit to interlock their entire system. This device can also be used to disengage heater power.

## **5 MAINTENANCE**

---

### **5.1 SPARE PARTS**

There are no spare parts for the IQ chemical heater.

### **5.2 PREVENTIVE MAINTENANCE SCHEDULE**

The IQ heater requires no preventive maintenance.

### **5.3 REMOVAL AND REPLACEMENT INSTRUCTIONS**

#### ***5.3.a Heater Replacement***

The IQ heater has been designed for quick replacement to minimize downtime and field service requirements. To replace a heater, use the following procedures:

- Shut down per Section 4.4.
- Turn power off to system (electrical and liquid).
- Drain liquid from heater housing (if present).
- Flush and/or decontaminate per company policy.
- Disconnect the electrical connection and interlocks to the heater.
- Drain liquid from the heater (if present).
- Disconnect the fluid inlet/outlet connections.
- Remove heater assembly.
- Install replacement heater per Section 3.
- Start up per Section 4.2.
- Contact Trebor or a factory authorized representative for return procedures, if required.

#### ***5.3.b Heater Decommissioning***

Heater assemblies removed from service, decommissioned, or dismantled should follow the steps outlines in Section 5.3.a for removing the heater assembly.

#### ***5.3.c Heater Disposal***

Heater assemblies being disposed are to be disposed of per company policy.

Residual housing chemistry can be drained per the heater housing drain port located on the inlet side of the heater. All drained chemistry is to be disposed of per company policy.

## 6 TROUBLESHOOTING

The following is an outline of routine troubleshooting techniques. For conditions not covered in this section consult Trebor or a factory authorized representative.

### 6.1 IRREGULAR TEMPERATURE CONTROL

SYMPTOM	CAUSES	SOLUTIONS
<ul style="list-style-type: none"> <li>Poor Temperature Control</li> </ul>	<ul style="list-style-type: none"> <li>Low liquid flow</li> <li>Location of outlet temperature sensor</li> <li>Incorrect control settings</li> </ul>	<ul style="list-style-type: none"> <li>Increase flow.</li> <li>Relocate outlet temperature sensor closer to heater outlet.</li> <li>Adjust control settings or scheme.</li> </ul>
<ul style="list-style-type: none"> <li>Heater Does Not Heat</li> </ul>	<ul style="list-style-type: none"> <li>Failed heater</li> <li>Wiring short</li> <li>Interlock alarm</li> <li>Control system error</li> </ul>	<ul style="list-style-type: none"> <li>Check heater element per Section 6.2.</li> <li>Check heater wiring.</li> <li>Address system alarms.</li> <li>Evaluate controller.</li> </ul>

### 6.2 HEATER ELEMENT CHECK

Lockout and Tagout power to the heater. Disconnect the heater power electrical connections and measure the resistance between power wires or to the neutral wire. Resistance should be less than the values listed in Table 6-1.

Heater Power	Power Wire to Power Wire	Power Wire to Neutral Wire
3-kW, 1Ø	<18Ω	N/A
4-kW, 1Ø	<15Ω	N/A
6-kW, 1Ø	<28Ω	N/A
3-kW, 3Ø	<106Ω	<53Ω
4-kW, 3Ø	<82Ω	<41Ω
6-kW, 3Ø	<52Ω	N/A

**Table 6-1: Element Resistance Check**

### 6.3 INTERLOCK SENSORS

ALARM	CAUSES	SOLUTIONS
<ul style="list-style-type: none"> <li>Liquid Leak</li> </ul>	<ul style="list-style-type: none"> <li>Liquid leak detected inside heater housing</li> <li>Sensor/wiring shorted or improperly wired to interlock</li> </ul>	<ul style="list-style-type: none"> <li>If liquid is present in the housing, decommission and replace heater per Section 5.3.</li> <li>Inspect/test sensor wiring.</li> </ul>
<ul style="list-style-type: none"> <li>Element Over-Temperature</li> </ul>	<ul style="list-style-type: none"> <li>No liquid or insufficient flow through the heater</li> <li>Insufficient control settings or scheme</li> <li>Sensor/wiring shorted or improperly wired to interlock</li> </ul>	<ul style="list-style-type: none"> <li>Increase flow rate.</li> <li>Modify control settings or scheme to limit the element to <math>\leq 250^{\circ}\text{C}</math>.</li> <li>Inspect/test sensor wiring.</li> </ul>
<ul style="list-style-type: none"> <li>Liquid Over-Temperature</li> </ul>	<ul style="list-style-type: none"> <li>Insufficient flow through the heater</li> <li>Insufficient control algorithm</li> <li>Sensor/wiring shorted or improperly wired to interlock</li> </ul>	<ul style="list-style-type: none"> <li>Increase flow rate.</li> <li>Check for blockage.</li> <li>Relocate outlet temperature sensor closer to heater outlet.</li> <li>Adjust control settings or scheme.</li> <li>Inspect/test sensor wiring.</li> </ul>
<ul style="list-style-type: none"> <li>Liquid Level</li> </ul>	<ul style="list-style-type: none"> <li>Insufficient liquid present in heater</li> <li>Liquid boiling</li> <li>Sensor/wiring shorted or improperly wired to interlock</li> </ul>	<ul style="list-style-type: none"> <li>Increase flow rate.</li> <li>Review liquid properties vs. conditions.</li> <li>Adjust sensor</li> <li>Inspect/test sensor wiring.</li> </ul>

## 7 WIRING SCHEMATIC

- Heater Wiring Schematic.

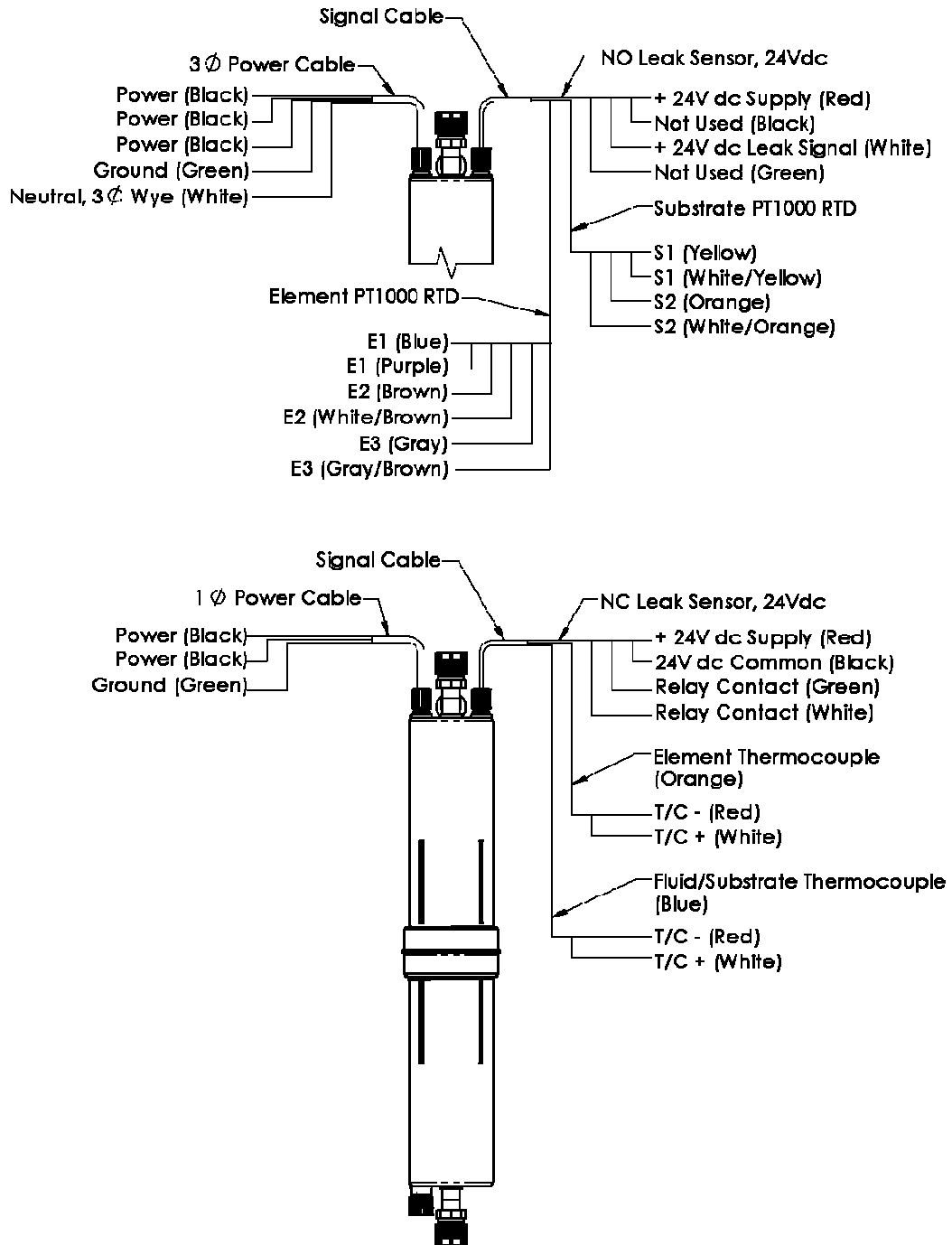
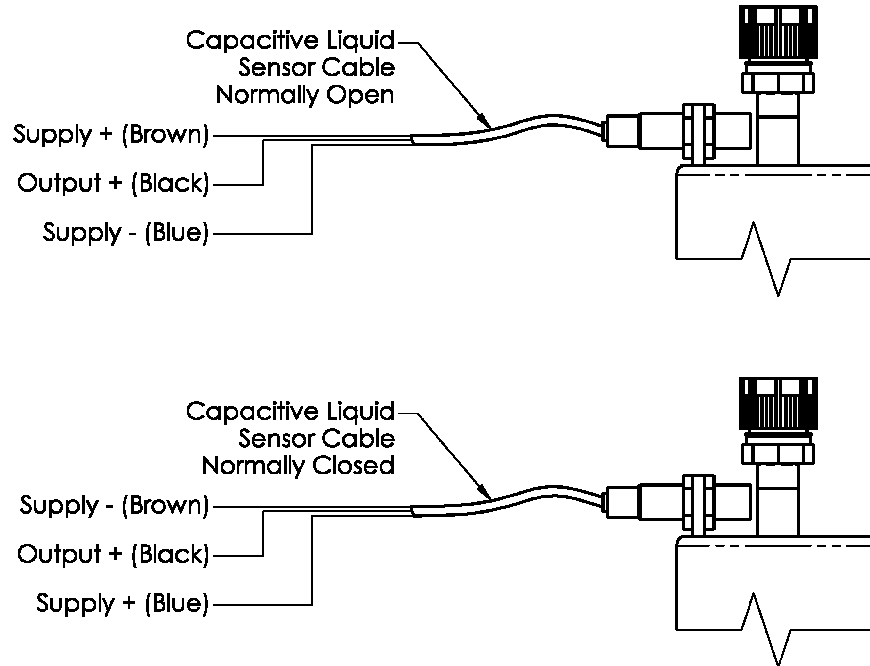

Figure 7-1

- Capacitive Liquid Sensor Wiring Schematic (10-36Vdc, PNP).



**Figure 7-2**

## **8 OPTIONS**

---

### **8.1 LEAK SENSOR**

- 24Vdc PNP style normally closed
- 24Vdc NPN style normally open

### **8.2 FLUID CONNECTIONS**

- ½" PFA Pipe Stub out (standard)
- ½" Flare
- ¾" Flare
- ¾" Super 300 Pillar®

Super 300 Type Pillar® is a registered trademark of Nippon Pillar Packing Co. LTD

### **8.3 LIQUID LEVEL SENSOR**

- Capacitive Liquid Sensor, 10-36Vdc PNP
- Optical Liquid Sensor

### **8.4 INTERLOCK TEMPERATURE SENSORS**

- Type "J" thermocouple (standard 1Ø)
- PT1000 RTD (2 wire, standard 3Ø)
- PT100 RTD (Optional)

## **9 WARRANTY AND EXCLUSIONS**

---

See the Trebor Standard Limited Warranty at

[www.idex-hs.com/support/trebor/downloads/TreborStandardLimitedWarranty\\_02-07.pdf](http://www.idex-hs.com/support/trebor/downloads/TreborStandardLimitedWarranty_02-07.pdf)

## 10 CONTACT INFORMATION

---

### 10.1 GENERAL CONTACT INFORMATION

Web: [www.idex-hs.com](http://www.idex-hs.com)

Phone Number: (801) 561-0303  
Toll Free Number: (800) 669-1303  
Fax Number: (801) 255-2312

Email: [treborinfo@idexcorp.com](mailto:treborinfo@idexcorp.com)  
[treborsales@idexcorp.com](mailto:treborsales@idexcorp.com)

Address: Trebor International  
8100 South 1300 West  
West Jordan, Utah 84088 U.S.A.

### 10.2 TECHNICAL SUPPORT

Email: [treborservice@idexcorp.com](mailto:treborservice@idexcorp.com)

Phone Number: (801) 244-6156

### 10.3 REGIONAL REPRESENTATIVES

Web: [www.idex-hs.com/about/distributors/trebor\\_distributors.aspx](http://www.idex-hs.com/about/distributors/trebor_distributors.aspx)