

MAXIM 50D PUMP

Operation / Maintenance Manual

CONTENTS

1	INSTALLATION	3
1.1	UNPACKING	3
1.2	UTILITIES / HOOK-UP	3
1.3	REMOTE EXHAUST HOOK-UP	4
2	OPTIONS	6
2.1	FLUID PORT CONNECTION OPTIONS.....	6
2.2	HOOK-UP WITH SURGE SUPPRESSOR.....	6
2.3	OPTIONAL LEAK SENSING	6
2.3.a	Installation.....	6
2.3.b	Sensor Signal Specifications	7
3	START-UP	8
3.1	PERFORMANCE CHARTS	8
4	MAINTENANCE	10
4.1	PREVENTIVE MAINTENANCE SCHEDULE	10
4.1.a	Preventive Maintenance Record.....	12
4.2	RECOMMENDED SPARE PARTS.....	13
4.3	TOOLS.....	13
4.4	PARTS ILLUSTRATION.....	14
4.5	PARTS LIST	15
4.6	CLEAN-UP.....	15
4.7	DISASSEMBLY.....	16
4.7.a	Body Disassembly	17
4.7.b	Head Disassembly.....	17
4.7.c	Control Base Disassembly.....	17
4.7.d	Cleaning.....	18
4.8	ASSEMBLY.....	18
4.8.a	Control Base Assembly	18
4.8.b	Body Assembly	19
4.8.c	Final Assembly	20
4.9	TESTING	22
4.9.a	Performance Test	22
4.9.b	Dry Pump.....	22
4.9.c	Dry Suction	22
5	TROUBLESHOOTING	23
6	WARRANTY	24
7	CONTACT INFORMATION	25
7.1	GENERAL CONTACT INFORMATION.....	25
7.2	TECHNICAL SUPPORT	25
7.3	REGIONAL REPRESENTATIVES	25

1 INSTALLATION

1.1 UNPACKING

After unpacking, the pump should be checked for any damage that may have occurred during shipment. Damage should be reported to the carrier immediately.

The following items should be included within the shipping container:

<u>Qty</u>	<u>Item</u>	<u>Description</u>
1	M50D	Maxim 50D Pump
1	MM50D	Operation/Maintenance Manual

1.2 UTILITIES / HOOK-UP

It is recommended that the pump be positioned within 15° from level to maintain self-priming ability and pumping efficiency. Allow sufficient room for tubing connectors. The pump mounts on a quick-change base for easy installation.

The pump has an exhaust location on the backside of the base. The exhaust location requires 1/2" (12mm) minimum clearance behind the control base. Care should be taken to elevate the pump whenever possible to help prevent flooding these ports when the pump is located in a wet bench plenum. For remote exhaust connection see Section 1.3.

Air Inlet: 1/4" NPTF (3/8" Dia. [8mm] supply tube minimum).

Fluid Ports: See Section 1.3. (All adapter port nuts should be torqued to 45in-lbs)

Air Supply: 20-80 psig (1.4 – 5.4 bar) clean dry air or nitrogen (See Performance Charts, Section 3.1.)

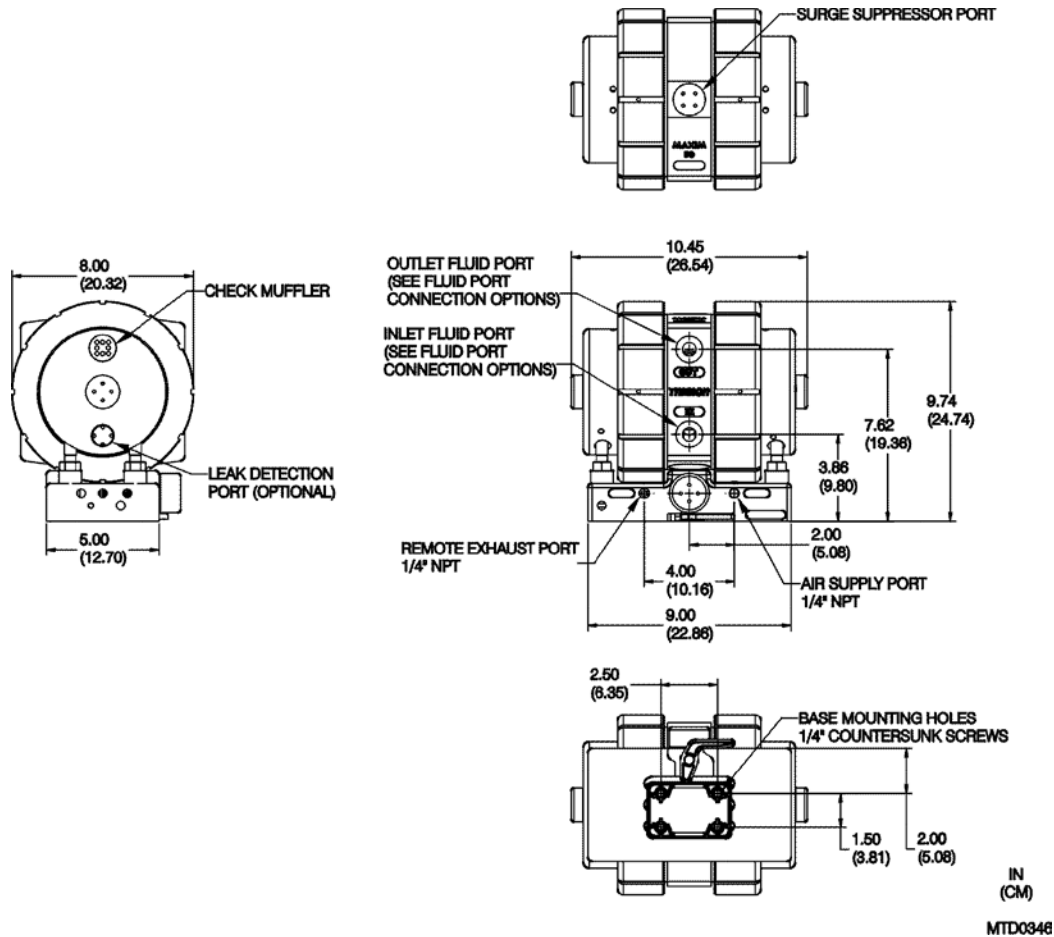

Figure 1-1

NOTE: It is recommended that a filter be placed on the discharge side of the pump.

Recommended Maximum Operating Levels: 80 psig (5.4 bar) from ambient to 80°C, 60 psig (4.1 bar) to 100°C

ATTENTION: The pump should be operated with clean, dry air or nitrogen. Particulate, water and oils in the air supply can damage the pump.

NOTE: New pumps may contain residual moisture from their final DI water test.

1.3 REMOTE EXHAUST HOOK-UP

- Remove existing Muffler Assembly from pump base.
- Install Exhaust Plug in Exhaust Port.
- Remove Pipe Plug (1/4" NPT) from the pump base. Install the appropriately sized fitting and tubing (not provided) to remote exhaust.

NOTE: To maintain optimum pump performance use 3/8" tubing minimum at a length of 10 ft. maximum.

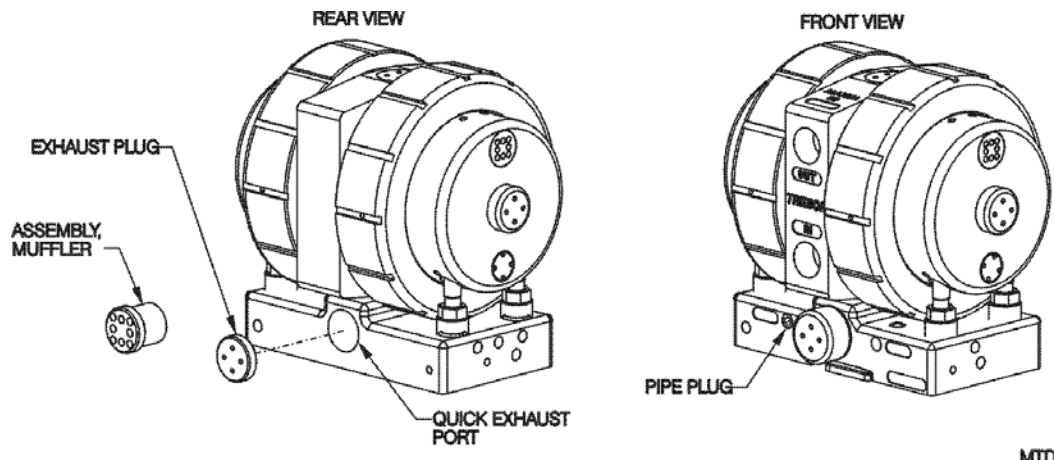

MTD0209

Figure 1-2

2 OPTIONS

2.1 FLUID PORT CONNECTION OPTIONS

NOTE: Use O-ring to seal stainless steel or other rigid plumbing.

Available Options

- 1/2" Flaretek (tube adapters)
- 3/4" Flaretek (tube adapters)
- 1" Flaretek (tube adapters)
- 3/4" NPT (adapter nuts)
- 3/4" PFA (stubout tube)
- 1/2" Purebond (pipe)

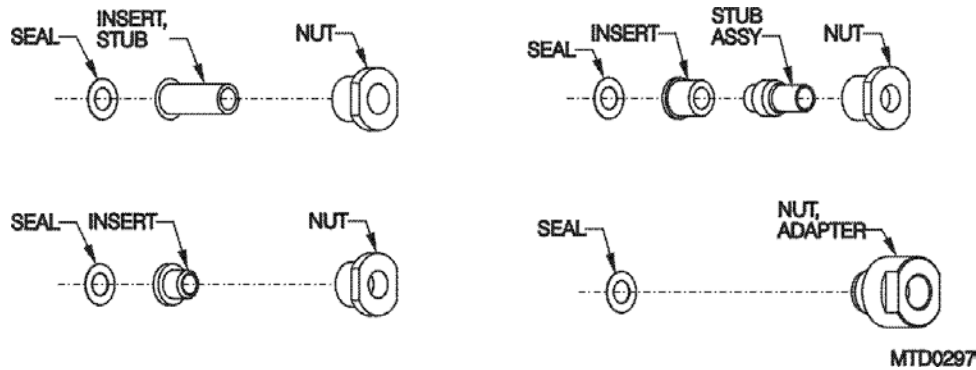

Figure 2-1

2.2 HOOK-UP WITH SURGE SUPPRESSOR

<u>Surge Suppressor</u>	<u>Assembled Height: IN (CM)</u>
MODEL 85	17.12 (43.49)
SS95	13.97 (35.48)

NOTE: See Surge Suppressor Operation Manual for detailed installation instructions.

2.3 OPTIONAL LEAK SENSING

2.3.a Installation

- Remove plug and seal from port. Probe is self-sealing.
- Install probe assembly into leak sensor port.
- Thread probe cap into port. (NOTE: **Do not over tighten**; damage to threads will occur.)
- Push protective tubing into probe cap.
- Connect fiber optic cable to sensor (NOTE: Minimize bends in fiber optic cable to 2" radius minimum to help ensure optimum signal strength.) Fiber optic cable can be cut to desired length using the cable cutter provided.

2.3.b Sensor Signal Specifications

- The sensor signal is normally closed. In the event of a leak, no light signal is returned to the sensor.

NOTE: See your fiber optic sensor installation instructions for proper hook-up and adjustment.

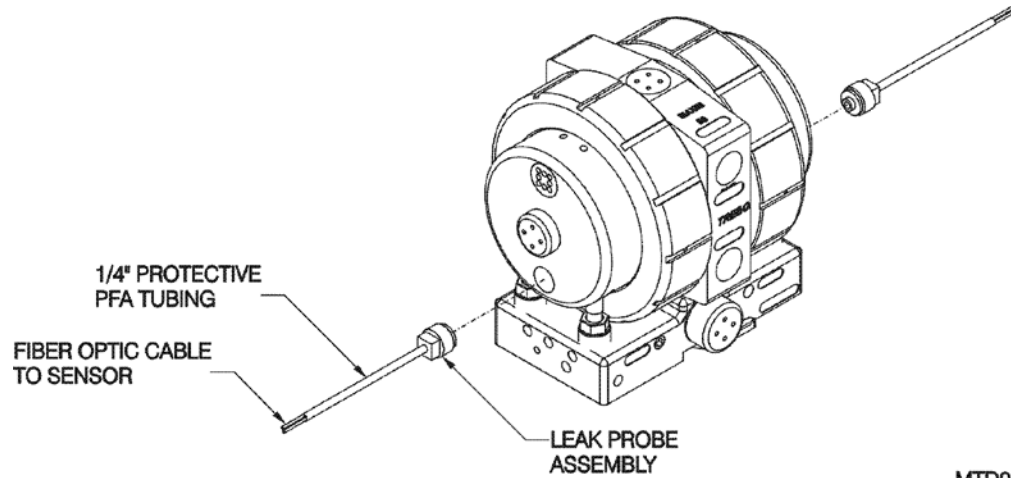

MTD0513

Figure 2-2

3 START-UP

- Pump air supply pressure must be regulated (< 80 psig).
- Open the fluid suction (IN) line valve, if necessary.
- Open the fluid discharge (OUT) line valve, if necessary.
- Start with air regulator at low (> 20 psi) pressure setting. Increase pressure to attain desired flow, up to the maximum rating (See Section 3.1).
- Table 1: Consumption / Efficiency can be used to determine approximate air consumption.
- Refer to Troubleshooting, Section 5, if pump fails to start.

ATTENTION: Prolonged periods (>5 minutes) of dry running can damage critical internal pump parts.



CAUTION: When handling potentially dangerous fluids under pressure, the pump and its fittings should be placed in an enclosure.

3.1 PERFORMANCE CHARTS

Pumping capacity is a function of air supply pressure and volume, suction head, suction line restrictions, discharge head, discharge line restriction, and fluid specific gravity and viscosity.

Air Supply Pressure (PSIG)	Discharge Fluid Pressure (PSIG)	Air Used (SCFM)
20	0	4.3
20	10	3.2
30	0	6.6
30	15	5.1
40	0	9.3
40	20	6.8
50	0	12.0
50	30	8.2
60	0	15.3
60	40	9.7

Table 1: Consumption / Efficiency

NOTE: Specification to be used to size regulators and control valves.

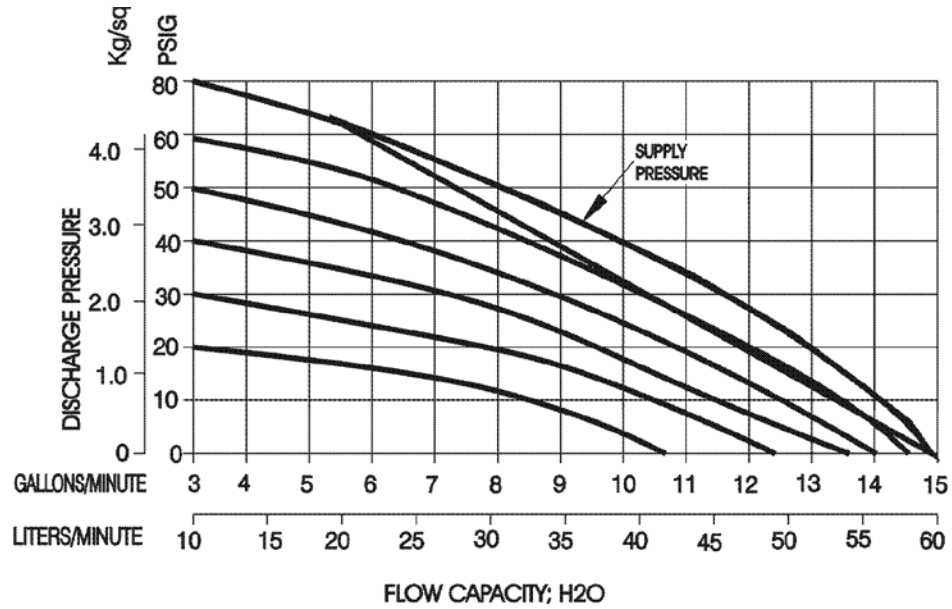

MTD0348

Figure 3-1: Pressure & Capacity Chart

NOTE: Test information is based on specific conditions and limited sampling. Use for general reference only. The diagram below shows the test bench layout used for ascertaining the performance information of Trebor pumps.

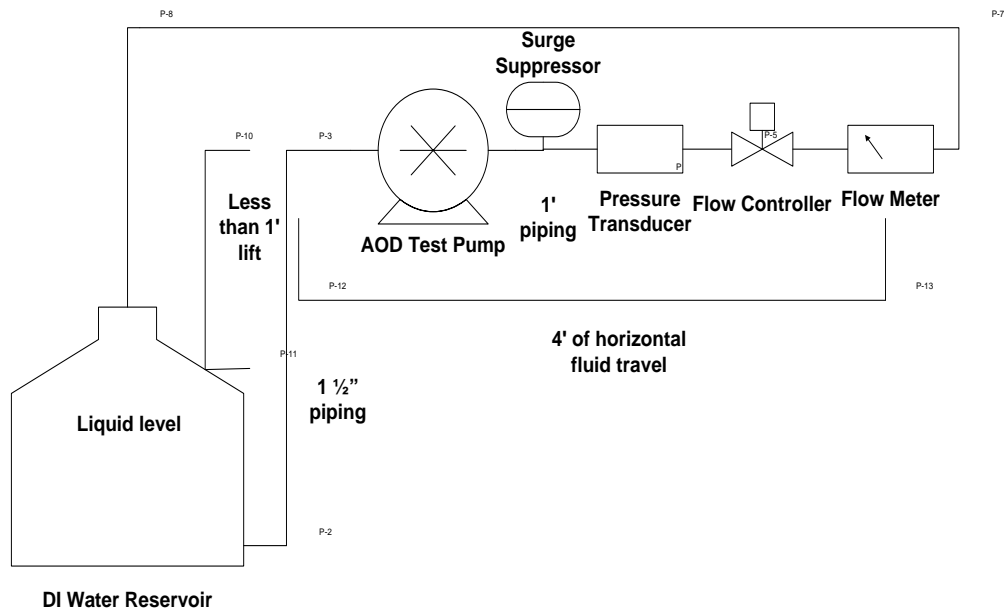

Figure 3-2

4 MAINTENANCE

Trebor pump maintenance can be divided into two categories: air system maintenance and fluid system maintenance. The purpose of air system maintenance is to prevent air system failures such as stalling or erratic cycling. The purpose of fluid system maintenance is to maintain suction and lift capabilities.

Pump Rebuild Service

Trebor International provides a factory rebuild service for customers using Trebor products. Trebor will rebuild any standard pump (exclusive of options). Please contact Trebor International Sales Department for current rebuild pricing. The fixed rebuild price includes a factory rebuild and parts equivalent to the standard rebuild kit. Each factory rebuild comes with a new one-year warranty. Repairs requiring more extensive part replacements will be quoted prior to proceeding with the pump rebuild. If the pump has exceeded its useful life and cannot be rebuilt, the customer may elect to purchase a new Trebor pump. If the customer chooses not to rebuild or replace the pump, a \$150.00 evaluation charge will be required.

All returned pumps are to be shipped freight prepaid with a valid Purchase Order for the cost of rebuild service. Please contact Trebor International prior to returning your pump to obtain an RMA Number and Pump Return Data Sheet to ensure proper safety precautions. Each pump will be evaluated and repaired within 5 working days of the receipt of pump at Trebor facility.

4.1 PREVENTIVE MAINTENANCE SCHEDULE

The following maintenance schedule is recommended to optimize pump performance and minimize failures. Certain operating conditions that require more frequent maintenance intervals have been noted. In positive pressure inlet conditions where suction or lift is not required, fluid system maintenance may be extended.

Adhering to the recommended preventative maintenance schedule along with periodic inspection of the pump will ensure continued efficient operation and overall reliable pump performance.

It is recommended that the Preventive Maintenance Record (Section 4.1.a) be copied, maintained and kept with this unit for future reference.

Maxim 50D

Replacement			Inspection				Component / Comments
6 Month	1 Year	2 Year	3 Month	6 Month	1 Year	2 Year	
		X					Muffler Media in Base
		X					C-Ring and Detent Legs
		X					Distribution Pilots
		X					Shaft and Shaft Seal
		X					Check Balls and O-Rings
						X	Check Seat, Suction Check, Discharge Check
		X					Diaphragms
		X					Check Plug Seals

4.1.a Preventive Maintenance Record

Company Name: _____

Company Address: _____

Product: _____ Serial Number: _____

Date: _____ Tech: _____ Notes: _____

Date: _____ Tech: _____ Notes: _____

Date: _____ Tech: _____ Notes: _____

Date: _____ Tech: _____ Notes: _____

Date: _____ Tech: _____ Notes: _____

Date: _____ Tech: _____ Notes: _____

Date: _____ Tech: _____ Notes: _____

Date: _____ Tech: _____ Notes: _____

Date: _____ Tech: _____ Notes: _____

Date: _____ Tech: _____ Notes: _____

Date: _____ Tech: _____ Notes: _____

Date: _____ Tech: _____ Notes: _____

Date: _____ Tech: _____ Notes: _____

Date: _____ Tech: _____ Notes: _____

Date: _____ Tech: _____ Notes: _____

Date: _____ Tech: _____ Notes: _____

Date: _____ Tech: _____ Notes: _____

Date: _____ Tech: _____ Notes: _____

Date: _____ Tech: _____ Notes: _____

Date: _____ Tech: _____ Notes: _____

Date: _____ Tech: _____ Notes: _____

Date: _____ Tech: _____ Notes: _____

Date: _____ Tech: _____ Notes: _____

Date: _____ Tech: _____ Notes: _____

4.2 RECOMMENDED SPARE PARTS

KR50D-00-B Spares Rebuild Kit, which includes:

<u>Part No</u>	<u>Qty</u>	<u>Description</u>
KM50D-00-B	1	Maintenance Kit Includes: (2) AK123 Distribution Pilot Assy (1) AK205 Muffler Assembly (2) L0197 Detent Leg (1) L0145 Detent Ring (2) AK127 Assembly, Muffler
KD50D-00-A	1	Diaphragm Kit Includes: (2) 1700C0047 Diaphragm (2) AK139 Wear Resist Diaphragm
98001415	4	Check Ball, PTFE
98002334	4	O-ring, -312 PTFE
98003079	2	Shaft Seal
AK004	1	Shaft
AK153	2	Check Cap Seal

In critical applications, a spare pump is recommended to minimize possible down time during service intervals.

4.3 TOOLS

The following tool kit is recommended as standard service equipment.

KT50-00-B Tool Kit, which includes:

<u>Part No</u>	<u>Qty</u>	<u>Description</u>
98003108	1	Torque Wrench, 30-150 ft/lb., 1/2" Drive
98003150	1	Tool Case, w/Foam, M50
98003305	1	Handle, Soc, 1/4" Drive
98003306	1	Wrench, Adj, 15/16"
T0126	1	Tool, Shaft Insert
T0129	1	Tool, Strap Wrench
T0132	1	Rebuild Fixture
T0144	1	Tool, Wedge, Head Removal, Cleaning Tool
T0146	1	Tool, Pin, 3/4x1/4 Drive
T0147	1	Tool, Pin, 1x1/4 Drive
T0148	1	Tool, Pin, 1/2x1/4 Drive
T0149	1	Tool, Pin, Optic Cap, 3/4

4.4 PARTS ILLUSTRATION

□ BORDERS REPRESENT FLUID CONTACT AREAS OF PUMP

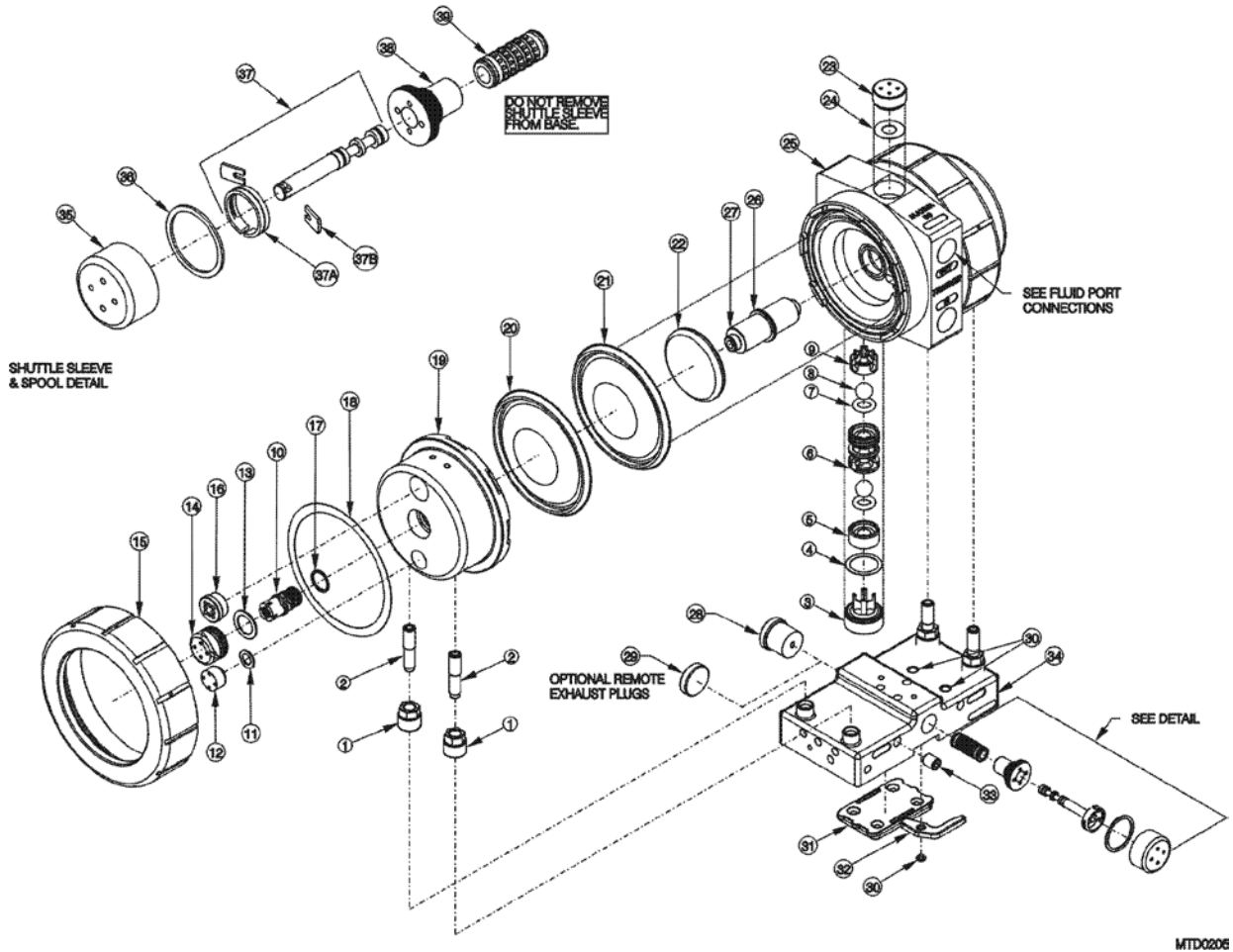

MTD0206

4.5 PARTS LIST

ILL NO	PART NO	QTY	DESCRIPTION	PM YEAR #	MATERIAL
1	98003277	4	Transfer Tube Nut		PP
2	AK182	4	Transfer Tube		PFA
3	AK149	2	Suction Plug		PTFE
4	AK153	2	Check Port Seal	2	PTFE
5	AK066	2	Suction Seat		PTFE
6	AK068	2	Suction Check		PTFE
7	98002334	4	O-Ring	2	PTFE
8	98001415	4	Check Ball	2	PTFE
9	AK026	2	Discharge Check Cage		PTFE
10	AK123	2	Wear Resist Pilot Assembly	1 & 2	PEEK, PTFE, PPS
11	AM037	2	Leak Port Seal		PTFE
12	AM040	2	Leak Port Plug		PP
13	AM020	2	Pilot Cap Seal		PTFE
14	AK116	2	Wear Resist Pilot Cap		PP
15	AK003	2	Union Nut		PP (PVDF optional)
16	AK127	2	Muffler Assembly	1 & 2	PP
17	AK120	2	Pilot Sleeve Seal		PTFE
18	AK097	2	Slip Washer		PTFE
19	AK119	2	Head		PP
20	AK139	2	Diaphragm, Wear Resistant	2	PTFE
21	1700C0047	2	Diaphragm, Maxim 50	2	PTFE
22	1700B0041	2	Push Plate		PTFE
23	AM075	1	Damper Plug		PTFE
24	AM084	1	Surge Port Seal		PTFE
25	AK065	1	Body		PTFE
26	98003079	2	Shaft Seal	2	PTFE
27	AK004	1	Shaft	2	PFA
28	AK205	1	Muffler Assembly	1 & 2	PP
29	1900B0072	1	Exhaust Plug (Optional for remote exhaust)		PP
30	98003071	3	Screw, PP		PP
31	AK088	1	Mounting Base		PP
32	AK108	1	Locking Lever		PP
33	98003080	2	1/4 NPT Fitting		PP
34	AK103	1	Control Base		PP
35	L0104	1	Detent Cap		PP
36	L0113	1	Detent Cap Seal		PTFE
37	L0131	1	Spool Assembly, High Load		Ceramic, PEEK, Torlon
37a	L0145	1	Detent Ring	1 & 2	PEEK
37b	L0197	2	Detent Leg	1 & 2	Torlon
38	L0105	1	Detent Adapter		PP
39	AK058	1	Shuttle Sleeve Assembly		Ceramic, PTFE

4.6 CLEAN-UP

To help remove potentially dangerous chemicals prior to service or shipment, the pump should be flushed with DI water or disassembled and thoroughly cleaned. Allow DI water to flush through the inlet and out the outlet to prevent pressure build up.

4.7 DISASSEMBLY

During the life of the pump it will be necessary to perform certain preventative maintenance procedures to ensure its continued high performance. This section and the next (4.8 Assembly) are provided for the user's convenience in disassembly and re-assembly procedures.

- Loosen quick grip nuts on the transfer tubes from the pump base using 13/16" open-end wrench.
- Remove pump assembly from the pump control base.
- Immerse or flush the pump assembly using DI water and a neutralizing agent.
- Install mounting fittings in pump adapter ports and lock body into bench mounting fixture. NOTE: Securely attach mounting fixture to work surface using hardware provided.

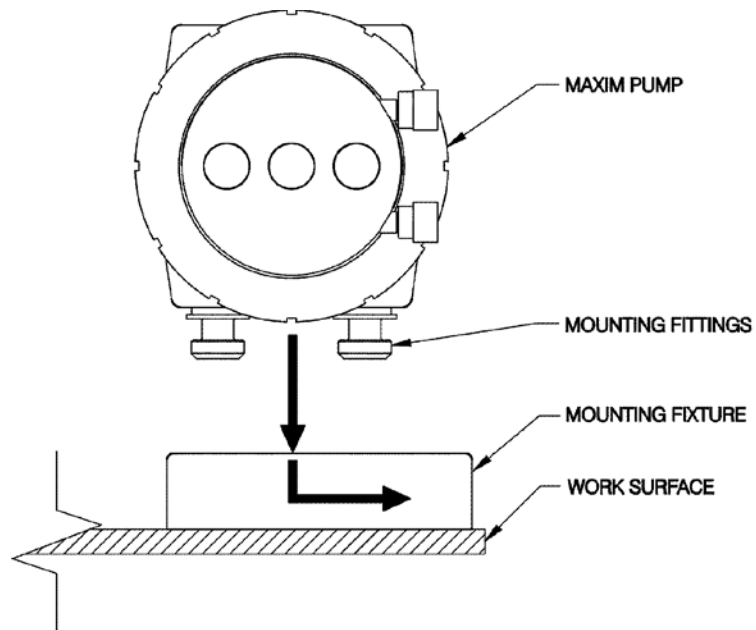

MTD0349

Figure 4-1

- Remove the transfer tubes from pump heads (using latex gloves to assist grip).
- Using strap wrench, turn union nuts counter-clockwise to remove.

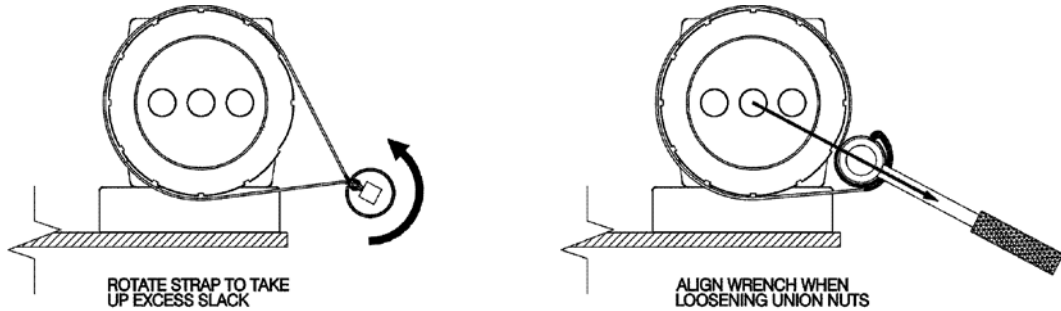

MTD0350

Figure 4-2

- Remove head and check diaphragms for cracks or cuts.
- To remove diaphragms, slit diaphragm with a sharp knife and pull the diaphragms from the grooves. **(Do not pry on diaphragm seal groove, as this will damage the sealing surface.)**
- Unscrew push plate from the shaft in a counter-clockwise direction. Pull other push plate and shaft from pump body.

ATTENTION: Following disassembly, parts should be thoroughly washed and be free from chemical residue for handling purposes.

4.7.a Body Disassembly

- Remove suction plugs and seal on bottom of pump body using 1" pin tool.
- Remove suction seat using 1" pin tool.
- Remove ball and O-ring.
- Unscrew suction check using 1" pin tool turning it counter-clockwise.
- Remove second set of O-rings and balls and pull out discharge check cage.
- Remove shaft seals from pump shaft seal groove in the center of the shaft bore using the tip of a razor knife. Take care not to damage the shaft bore. NOTE: Do not reuse seals.
- Remove damper plug and seal using 3/4" pin tool.

4.7.b Head Disassembly

- Unscrew and remove pilot cap using the 3/4" pin tool
- Remove seal.
- Unscrew and remove pilot assembly using 3/4" pilot pin tool and seal.

4.7.c Control Base Disassembly

- Unlock control base from quick-change mount by pulling out lever on front of base to unlock mount. Then slide base back until it stops. Lift base off mount.
- Using pH test strips evaluate whether base has any contamination in air passages, especially the muffler area. If present, neutralize using best methods prior to disassembly.

- Unscrew and remove muffler assembly from base using the 1" pin tool.
- Unscrew and remove the shuttle cap and seal.
- Remove shuttle spool assembly from detent adapter.
- Remove detent legs and detent ring from spool.
- Remove detent adapter from base using 3/4" pin tool.
- **Do not remove** the shuttle sleeve from the shuttle bore.

4.7.d Cleaning

- Gently spray clean or dunk rinse all components with DI water to remove any trace materials remaining after disassembly.

4.8 ASSEMBLY

Prior to beginning assembly, inspect all parts to ensure they are clean and dry. Wear clean protective gloves. Precautions should be exercised to prevent contaminating any of the air chamber surfaces with chemicals during handling.

4.8.a Control Base Assembly

- Thread detent adapter into shuttle bore using 3/4" pin tool. (Detent adapter must be flush against base as shown.) torque to 45in-lbs.

Shuttle spool assembly instructions:

- Hold shuttle spool (item 1) upright and align slot and in detent legs (item 2) with notch on shuttle spool, see Fig 1.
- Apply pressure upward onto base of detent legs with thumb and index finger, as shown in Fig. 2.
- Tilt the detent ring (item 3) over one of the legs, and align the groove on the inside of the detent ring with the end of the detent leg. Tilt the other side of the ring down, expanding it slightly, so that the other detent leg snaps into the detent ring groove. See Fig. 3. The completed assembly should look like Fig. 4 (see Figure 4-3).

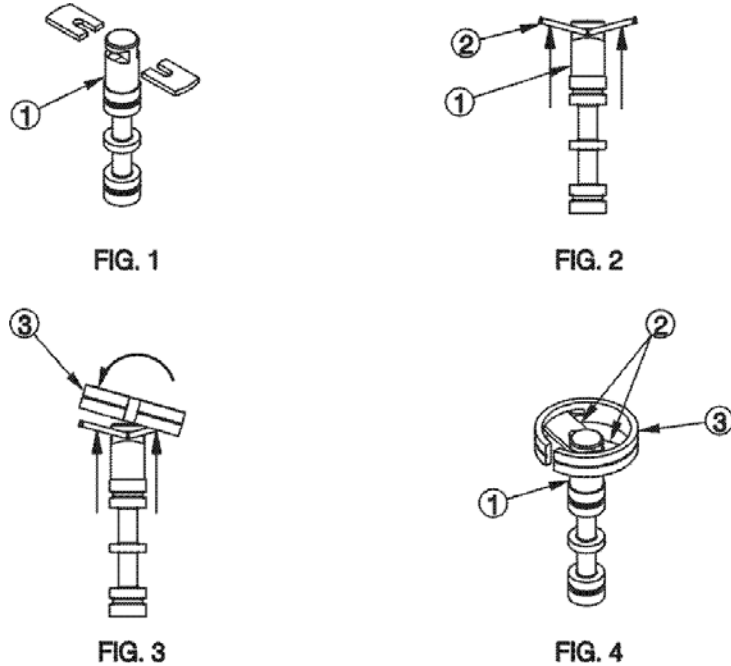

MTD0312

Figure 4-3

- Insert spool assembly into detent adapter and shuttle sleeve (do not lubricate spool or sleeve).
- Install seal onto seal groove shoulder
- Thread shuttle cap onto detent adapter, torque to 40in-lbs.

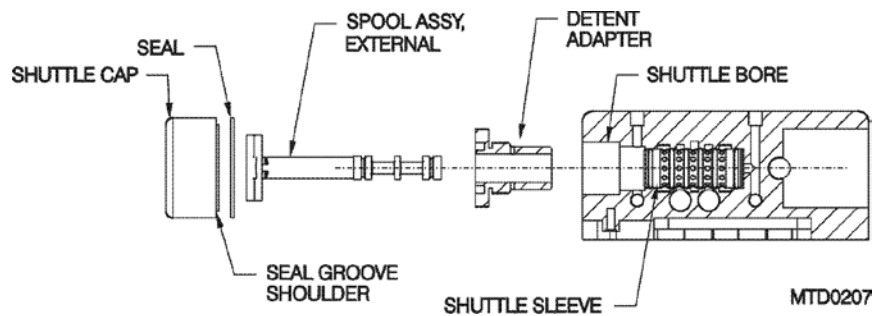

MTD0207

Figure 4-4

ATTENTION: Threads should be snug. Do not over tighten.

- Thread muffler assembly into base using 1" pin tool, torque to 40in-lbs.

4.8.b Body Assembly

- Install seal and damper plug into body using 3/4" pin tool, torque to 50in-lbs.
- Remove pump from assembly fixture.
- Turn pump upside down to access check bores.

- Install discharge check cage into bore making sure small end fits into relief in bottom of bore.
- Drop ball into check cage, then O-ring.
- Install suction sleeve into the bore; tighten using 1" pin tool. Tighten until engagement with O-ring is achieved, then unthread the sleeve a quarter turn. **Do not** over tighten as damage may occur.
- Install second ball into check cage, then O-ring.
- Install suction seat using the 1" pin tool. Tighten until engagement with O-ring is achieved, then unthread the seat a quarter turn.
- Install check seal onto check bore shoulder and thread suction plug into bore using 1" pin tool, torque to 60in-lbs.
- Repeat for the second bore.
- Install two shaft seals in shaft bore groove with slits 180° apart.
- Thread push plate onto main shaft until engagement with the shaft shoulder is achieved. Additionally apply a ¼" turn to ensure proper installation.
- Thread shaft onto shaft insert tool and insert shaft into bore.

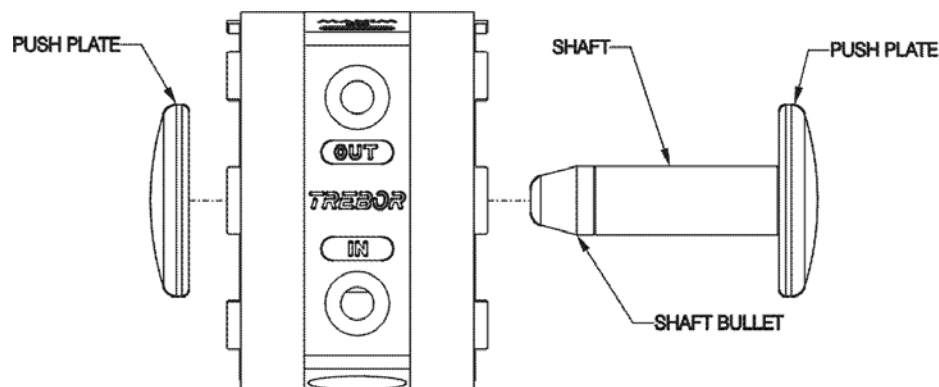

MTD0351

Figure 4-5

- Remove shaft insert tool and thread second push plate until engagement with the shaft shoulder is achieved. Additionally apply a ¼" turn to ensure proper installation.

4.8.c Final Assembly

- Reattach pump to assembly fixture.
- Attach union nut to one side of pump body (hand tight). Do not install diaphragm on this step. This will protect body during initial pump assembly.
- Remove pump from the assembly fixture.
- Place pump body with union nut down and place two diaphragms, removing all air from between diaphragms, with "V" groove point toward the body.
NOTE: Make sure wear disk is on diaphragm surface closest to head.

- Install head on body. Note tab alignment and orientation of transfer tube ports in head.
- Install union nut on pump while gently pressing down on the head to engage tabs in head and body, spin union nut down hand tight.
- Turn pump over and remove union nut to install diaphragms.
- Repeat diaphragm, head and union installation.
- Lock body into mounting fixture.
- Using strap wrench, torque union nuts slowly to 75 ft-lbs with the wrench at 90° +/- 15° to the nut's surface as shown.

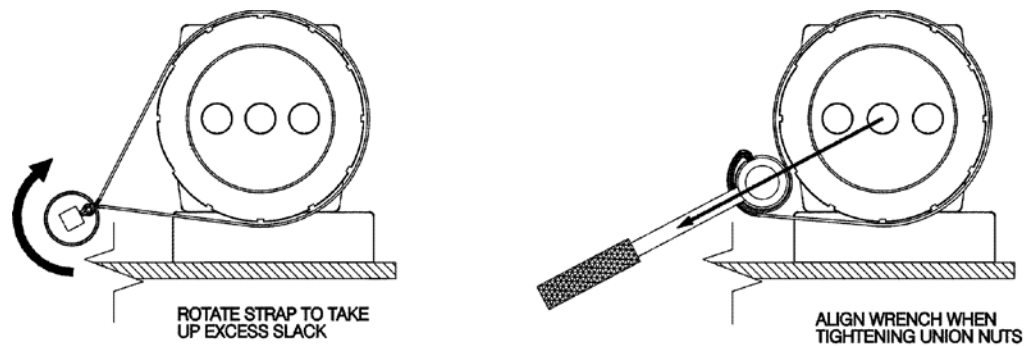

MTD0352

Figure 4-6

- Wrap each transfer tube with 3 wraps of Teflon tape and reinstall into the head ports using latex gloves for added grip. Leave a protrusion height of 2" for each transfer tube.
- Thread pilot assembly and seal into head using 3/4" pilot centering pin tool, torque to 35in-lbs.
- Position pilot cap seal into bore and thread in pilot cap using 3/4" pin tool, torque to 30in-lbs.
- Position control base on mounting base, slide base forward, use locking lever to secure.
- Ensure that the ferrule of the quick grip nut is inserted into the transfer tube port of the base. Place the gripper seal on top of the ferrule with the tapered end facing up.
- Loosely attach quick grip nuts to transfer tube ports on control base taking care not to dislocate the ferrule and gripper seal.
- Install pump onto control base by inserting transfer tubes in pump into quick grip nuts on control base.
- To secure pump to control base, tighten quick grip nuts one (1) full turn past hand tight using 13/16" wrench.
- Reconnect both air supply and fluid lines.

4.9 TESTING

4.9.a Performance Test

- With the air supply at 0 psi open the air supply valve
- Increase the air pressure until the pump starts to cycle
- Record the start pressure, Target = <20psig
- Pump must prime once even cycling is achieved
- Increase pressure to 60 psi
- Check for fluid leaks & listen for air leaks
- Ensure that the pump does not cycle erratically
- Close the discharge valve and deadhead for 2 minutes
- Pump must not experience machine gunning, erratic cycling or leaks
- Open discharge valve and expel the remaining DI water
- Prepare the pump for drying

4.9.b Dry Pump

- Connect vacuum hose to discharge line
- Connect purge line to fluid inlet
- 60 psig Supply Pressure
- Cycle pump & vacuum dry by rotating pump side to side for 30 seconds.
- Turn off Air Supply and allow the pump to purge for 5 minutes.

4.9.c Dry Suction

- 20 psig Supply Pressure Target
- Record Suction Value
- Target = 12 in-Hg.

5 TROUBLESHOOTING

Pump Will Not Start, Fails to Operate

Cause:

- Insufficient air pressure.
- Insufficient air volume (low supply pressure during running).
- Fluid discharge line blocked. Downstream valve closed, filter plugged or other obstruction.
- Pilot valve failure.
- Detent failure.

Solution:

- Must be minimum 20 psig at pump air hook-up.
- See Performance Charts (3.1) for requirements. Check for both regulator and control valve capabilities.
- Remove obstruction.
- Inspect and replace pilot valve assembly if sticky.
- Inspect detent legs for worn or damaged parts.

Bubbles in Fluid Discharge

Cause:

- Leaking fluid inlet fitting.
- Leaking main seal.
- Pump inlet line pressure reached saturation point (due to high suction requirement).
- Ruptured (perforated) diaphragm.
- Check bore caps leaking.

Solution:

- Replace adapter seal.
- Tighten union nut to 75 ft-lbs. or replace diaphragms, and check head and body seal grooves for nicks or scratches.
- Increase diameter of suction supply line (reduces restriction).
Reduce output flow.
- Replace diaphragms.
- Tighten check bore caps or replace seals.

Fluid Leaks

Cause:

- Union nut torque not enough to effect seal.
- Leaking main seal.
- Check bore cap.
- Ruptured diaphragm(s) can result in fluid leaks through air exhaust port.

Solution:

- Tighten union nuts to 75 ft-lbs.
- Replace diaphragms.
Check head and body seal grooves for nicks or scratches.
- Tighten, or remove and replace seal.
- Replace diaphragms, and any parts that may have been damaged by fluid exposure.

Erratic Cycling

Cause:

- Pilot valve failure.
- Suction line restricted (cavitation).
- Detent failure.
- Check ball(s) not seating.
- Over pressurization of pump discharge.

Solution:

- Inspect and replace pilot valve assembly.
- Reduce fluid restriction.
- Inspect and replace spool assembly.
- Check O-rings for damage; replace if necessary.
Make sure check balls move freely in sleeves.
- Reduce discharge pressure by reducing restriction.

6 WARRANTY



See the Trebor Standard Limited Warranty at
www.idex-hs.com/support/trebor/downloads/TreborStandardLimitedWarranty_02-07.pdf

7 CONTACT INFORMATION

7.1 GENERAL CONTACT INFORMATION

Web: www.idex-hs.com
Phone Number: (801) 561-0303
Toll Free Number: (800) 669-1303
Fax Number: (801) 255-2312
Email: treborinfo@idexcorp.com
treborsales@idexcorp.com
Address: Trebor International
8100 South 1300 West
West Jordan, Utah 84088 U.S.A.

7.2 TECHNICAL SUPPORT

Email: treborservice@idexcorp.com
Phone Number: (801) 244-6156

7.3 REGIONAL REPRESENTATIVES

Web: www.idex-hs.com/about/distributors/trebor_distributors.aspx