

MAXIM 50E/U PUMP

External Controlled

Operation / Maintenance Manual

CONTENTS

1	INSTALLATION	3
1.1	UNPACKING	3
1.2	UTILITIES / HOOK-UP	3
1.3	PROBE ASSEMBLY INSTALLATION (E MODEL ONLY)	4
1.4	PLC CONTROL SCHEMATIC	5
1.5	REMOTE EXHAUST HOOK-UP	6
2	OPTIONS	7
2.1	FLUID PORT CONNECTION OPTIONS	7
2.2	HOOK-UP WITH SURGE SUPPRESSOR	7
2.3	OPTIONAL LEAK SENSING	7
2.3.a	Installation	7
2.3.b	Sensor Signal Specifications	8
3	START-UP	9
3.1	PERFORMANCE CHARTS	9
4	MAINTENANCE	12
4.1	PREVENTIVE MAINTENANCE SCHEDULE	12
4.1.a	Preventive Maintenance Record	14
4.2	RECOMMENDED SPARE PARTS	15
4.3	TOOLS	15
4.4	PARTS ILLUSTRATION	16
4.5	PARTS LIST	17
4.6	CLEAN-UP	17
4.7	DISASSEMBLY	17
4.7.a	Body Disassembly	19
4.7.b	Control Base Disassembly	19
4.7.c	Cleaning	19
4.8	ASSEMBLY	19
4.8.a	Control Base Assembly – Quick Exhaust	19
4.8.b	Body Assembly	20
4.8.c	Final Assembly	21
4.9	TESTING	22
4.9.a	Performance Test	22
4.9.b	80/80 Leak Test	22
4.9.c	Dry Pump	22
4.9.d	Dry Suction	23
4.10	MAXIM PUMP LADDER LOGIC CONTROL EXAMPLE	23
4.10.a	Oscillator Control (No Probes Required)	23
4.10.b	End-Of-Stroke Control	25
4.10.c	Combination End-Of-Stroke & Oscillator Reset	27
5	TROUBLESHOOTING	31
6	WARRANTY	32
7	CONTACT INFORMATION	33
7.1	GENERAL CONTACT INFORMATION	33
7.2	TECHNICAL SUPPORT	33
7.3	REGIONAL REPRESENTATIVES	33

1 INSTALLATION

1.1 UNPACKING

After unpacking, the pump should be checked for any damage that may have occurred during shipment. Damage should be reported to the carrier immediately.

The following items should be included within the shipping container:

<u>Qty</u>	<u>Item</u>	<u>Description</u>
1	M50E/U	Maxim 50E/U Pump
1	MM50E/U	Operation/Maintenance Manual
2	DP-C-12	End-of-Stroke Probe (E Model only)
1	98002986	Fiber Optic Cable Cutter

1.2 UTILITIES / HOOK-UP

It is recommended that the pump be positioned within 15° from level to maintain self-priming ability and pumping efficiency. Allow sufficient room for tubing connectors. The pump mounts on a quick-change base for easy installation.

The pump has dual exhaust locations on the backside of the base. The exhaust locations require 1/2" (12mm) minimum clearance behind the control base. Care should be taken to elevate the pump whenever possible to help prevent flooding when the pump is located in a wet bench plenum. For remote exhaust connection see Section 1.5.

Air Inlet: 1/4" NPTF (3/8" Dia. [8mm] supply tube minimum).

Fluid Ports: See Section 1.3. (All adapter port nuts should be torqued to 45in-lbs)

Air Supply: 20-80 psig (1.4 – 5.5 bar) clean dry air or nitrogen (see Performance Charts, Section 3.1). NOTE: See Figure 3-2: Pressure vs. Fluid Temperature Chart.

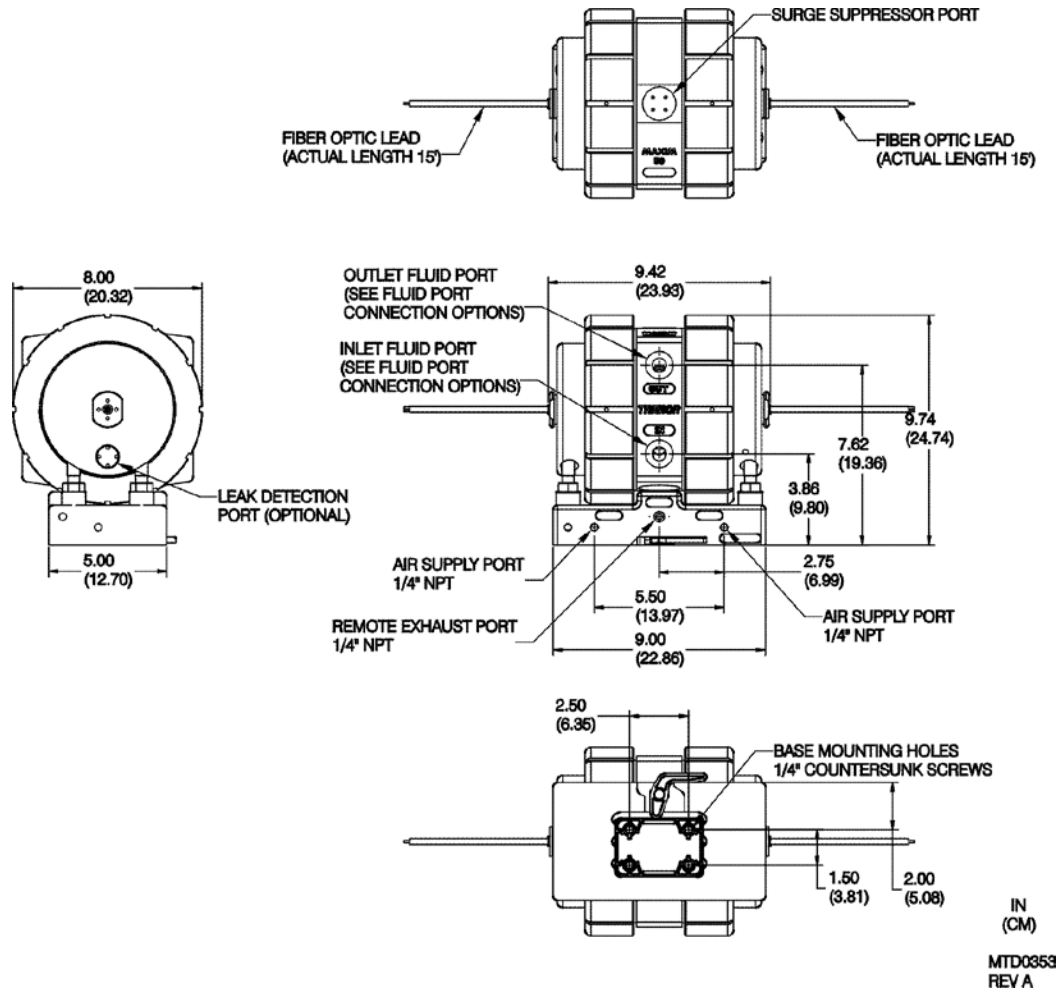

Figure 1-1

NOTE: It is recommended that a filter be placed on the discharge side of the pump.

Recommended Maximum Operating Levels: 80 psig (5.5 bar) ambient to 80°C, 60 psig (4.1 bar) to 100°C, 45 psig (3.1 bar) air supply when operating above 100°C (See Figure 3-2: Pressure vs. Fluid Temperature Chart)

ATTENTION: The pump should be operated with clean, dry air or nitrogen. Particulate, water and oils in the air supply can damage the pump.

NOTE: Although extensive efforts are made to deliver pumps to our customers completely dry, new pumps may contain residual moisture from their final DI water test.

1.3 PROBE ASSEMBLY INSTALLATION (E MODEL ONLY)

Optic Cable: 1mm core; 1/4" PFA protective tubing.

- Install seal into head.

- Install probe assembly into head.
- Thread probe cap into head hand tight only, no tool needed.
- Connect fiber optic cable to sensor. NOTE: Minimize bends in fiber optic cable to 2" radius minimum to help ensure optimum signal strength. NOTE: Standard cable length is 15 ft. [4.57 meters].

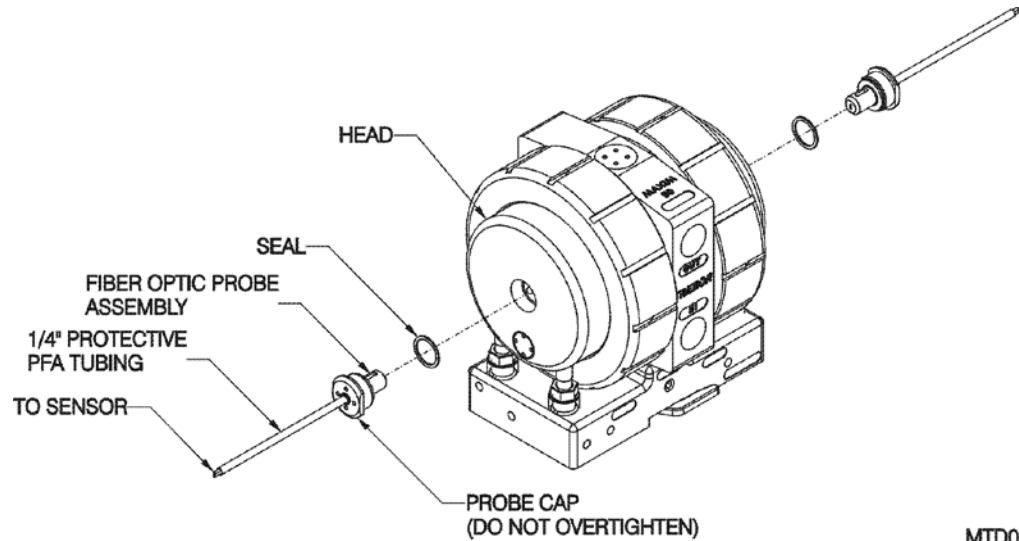

Figure 1-2

1.4 PLC CONTROL SCHEMATIC

Shown below is an example of the fiber optic end of stroke detection for a Maxim Pump. The Programmable Logic Controller (PLC) control schematic shown will allow the Maxim to be controlled by a PLC. Some of the features that can be programmed are:

- Start and stop pump
- Monitoring approximate flow rate
- Leak sensing
- High and low flow rate detection
- Preventative maintenance counter
- Cycle counting
- Oscillator control override

NOTE: See examples of ladder logic programs in Section 4.10.

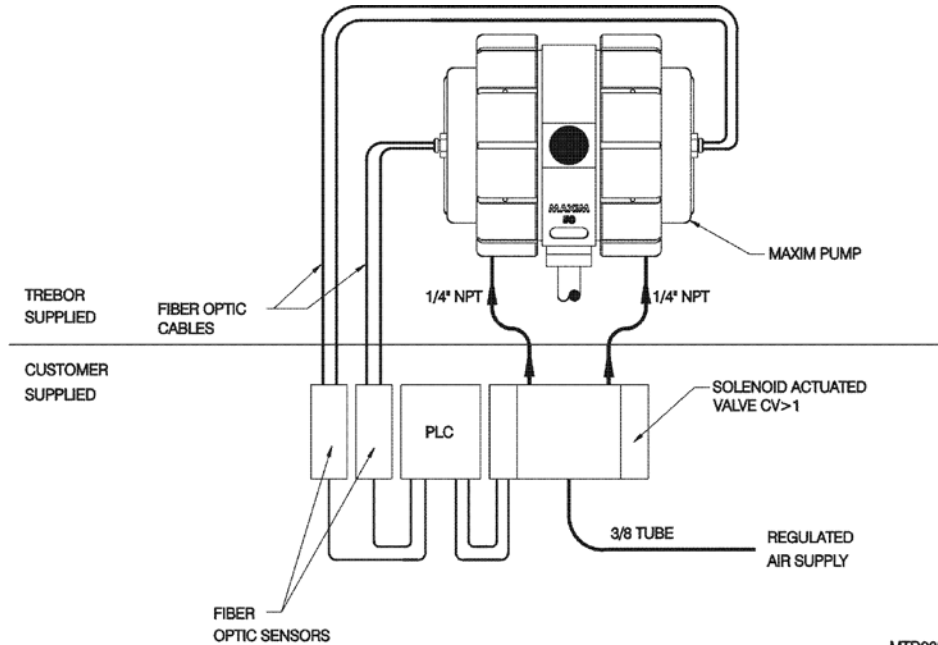

MTD0355

Figure 1-3

1.5 REMOTE EXHAUST HOOK-UP

- Remove existing Muffler Assembly from pump base.
- Install Exhaust Plugs in Quick Exhaust Ports.
- Remove Pipe Plug (1/4" NPT) from the pump base. Install the appropriately sized fitting and tubing (not provided) to remote exhaust.

NOTE: To maintain optimum pump performance use 3/8" tubing minimum at a length of 10 ft. maximum.

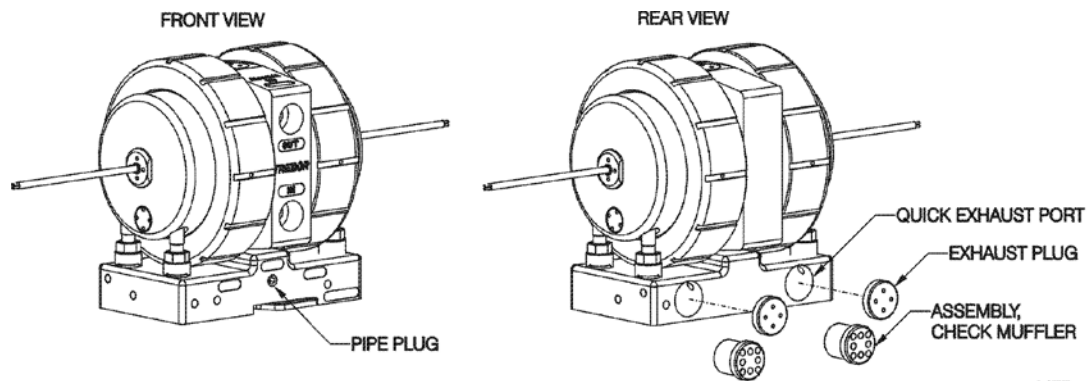

MTD0356

Figure 1-4

2 OPTIONS

2.1 FLUID PORT CONNECTION OPTIONS

NOTE: Use O-ring to seal stainless steel or other rigid plumbing.

Available Options

- 1/2" Flaretek (tube adapters)
- 3/4" Flaretek (tube adapters)
- 1" Flaretek (tube adapters)
- 3/4" NPT (adapter nuts)
- 3/4" PFA (stubout tube)
- 1/2" Purebond (pipe)

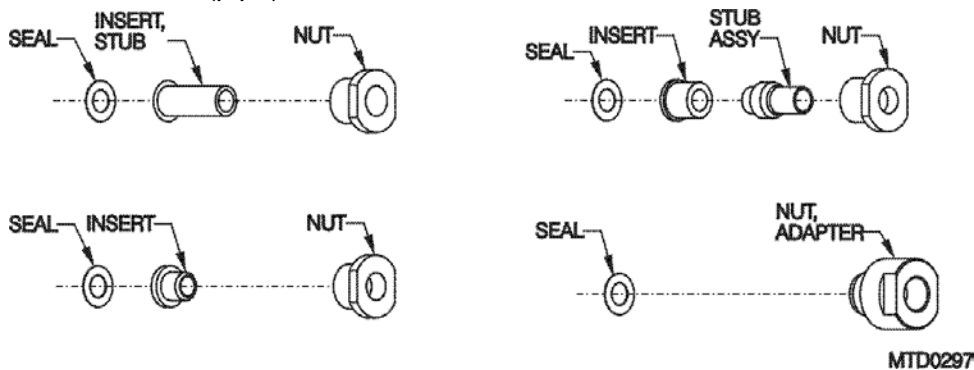

Figure 2-1

2.2 HOOK-UP WITH SURGE SUPPRESSOR

Surge Suppressor	Assembled Height: IN (CM)
MODEL 85	17.12 (43.49)
SS95	13.97 (35.48)

NOTE: See Surge Suppressor Operation Manual for detailed installation instructions.

2.3 OPTIONAL LEAK SENSING

2.3.a Installation

- Remove plug and seal from port. Probe is self-sealing.
- Install probe assembly into leak sensor port.
- Thread probe cap into port. (NOTE: **Do not over tighten**; damage to threads will occur.)
- Push protective tubing into probe cap.
- Connect fiber optic cable to sensor (NOTE: Minimize bends in fiber optic cable to 2" radius minimum to help ensure optimum signal strength.) Fiber optic cable can be cut to desired length using the cable cutter provided.

2.3.b Sensor Signal Specifications

- The sensor signal is normally closed. In the event of a leak, no light signal is returned to the sensor.

NOTE: See your fiber optic sensor installation instructions for proper hook-up and adjustment.

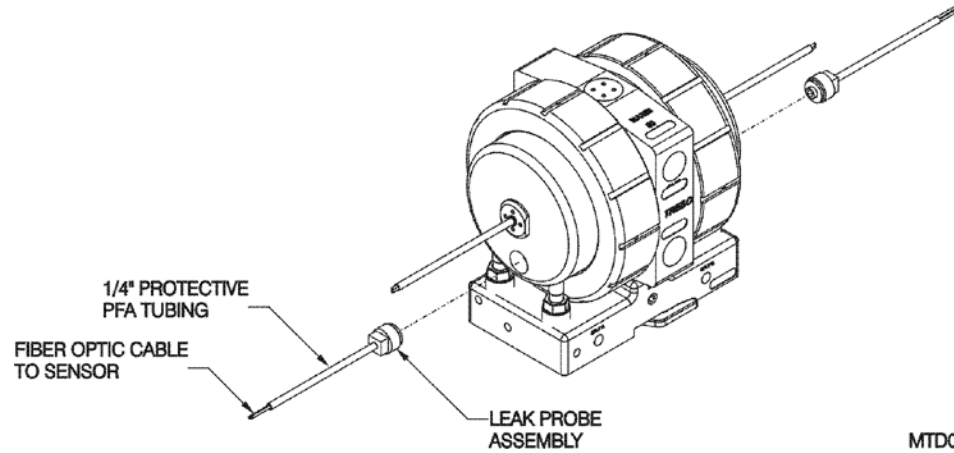

MTD0514

Figure 2-2

3 START-UP

- Pump air supply pressure should be regulated. (See Figure 3-2: Pressure vs. Fluid Temperature Chart)
- Open the fluid suction (IN) line valve, if necessary.
- Open the fluid discharge (OUT) line valve, if necessary.
- Start with air regulator at low (> 20 psi) pressure setting. Increase pressure to attain desired flow, up to the maximum rating (See Section 3.1).
- Table 1: Consumption / Efficiency can be used to determine approximate air consumption.
- Refer to Troubleshooting, Section 5, if pump fails to start.

ATTENTION: Prolonged periods (>5 minutes) of dry running can damage critical internal pump parts.



CAUTION: When handling potentially dangerous fluids under pressure, the pump and its fittings should be placed in a compatible enclosure.

3.1 PERFORMANCE CHARTS

Pumping capacity is a function of air supply pressure and volume, suction head, suction line restrictions, discharge head, discharge line restriction, and fluid specific gravity and viscosity.

Air Supply Pressure (PSIG)	Discharge Fluid Pressure (PSIG)	Air Used (SCFM)
20	0	4.3
20	10	3.2
30	0	6.6
30	15	5.1
40	0	9.3
40	20	6.8
50	0	12.0
50	30	8.2
60	0	15.3
60	40	9.7
80	0	19.0
80	50	12.6

Table 1: Consumption / Efficiency

NOTE: Specification to be used to size regulators and control valves.

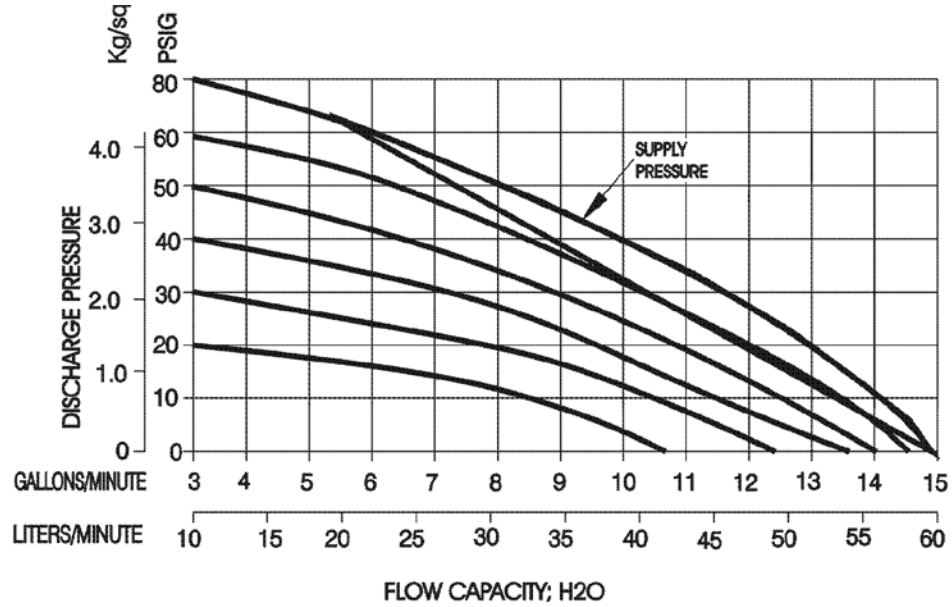

MTD0348

Figure 3-1: Pressure & Capacity Chart

NOTE: Test information is based on specific conditions and limited sampling. Use for general reference only. The diagram below shows the test bench layout used for ascertaining the performance information of Trebor pumps.

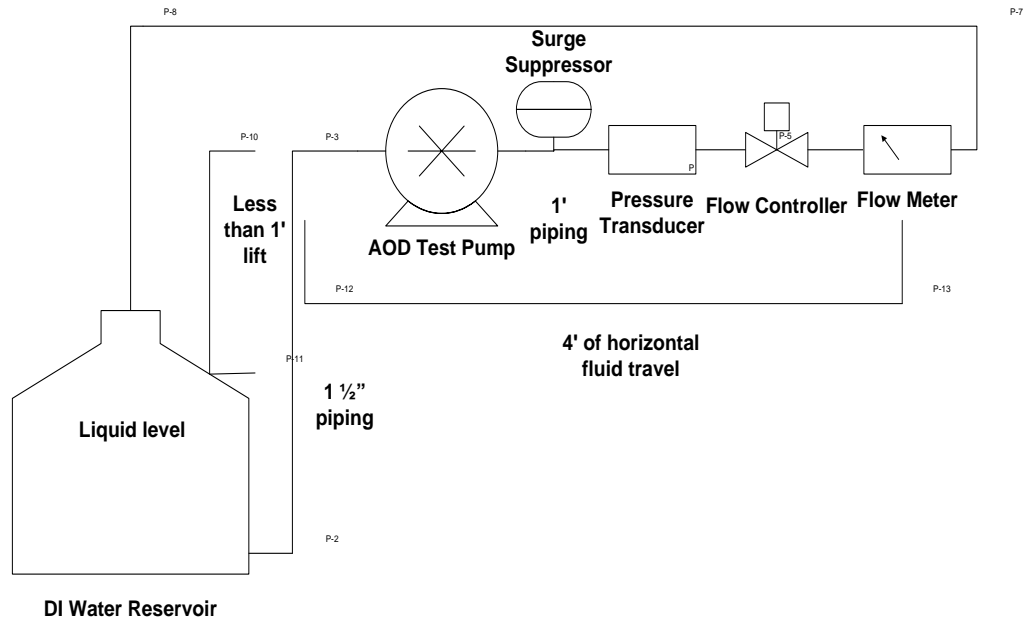
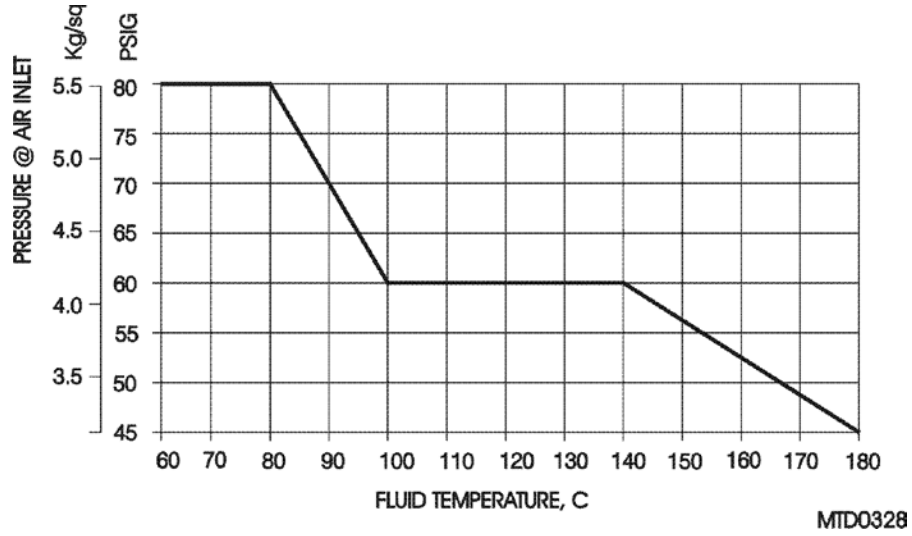

Figure 3-2



**Figure 3-3: Pressure vs. Fluid Temperature Chart
Recommended Maximum Pump Operating Pressure**

NOTE: Be sure that fittings and tubing used are capable of these operating conditions.

4 MAINTENANCE

Trebor pump maintenance can be divided into two categories: air system maintenance and fluid system maintenance. The purpose of air system maintenance is to prevent air system failures such as stalling or erratic cycling. The purpose of fluid system maintenance is to maintain suction and lift capabilities.

Pump Rebuild Service

Trebor International provides a factory rebuild service for customers using Trebor products. Trebor will rebuild any standard pump (exclusive of options). Please contact Trebor International Sales Department for current rebuild pricing. The fixed rebuild price includes a factory rebuild and parts equivalent to the standard rebuild kit. Each factory rebuild comes with a new one-year warranty. Repairs requiring more extensive part replacements will be quoted prior to proceeding with the pump rebuild. If the pump has exceeded its useful life and cannot be rebuilt, the customer may elect to purchase a new Trebor pump. If the customer chooses not to rebuild or replace the pump, a \$150.00 evaluation charge will be required.

All returned pumps are to be shipped freight prepaid with a valid Purchase Order for the cost of rebuild service. Please contact Trebor International prior to returning your pump to obtain an RMA Number and Pump Return Data Sheet to ensure proper safety precautions. Each pump will be evaluated and repaired within 5 working days of the receipt of pump at Trebor facility.

4.1 PREVENTIVE MAINTENANCE SCHEDULE

The following maintenance schedule is recommended to optimize pump performance and minimize failures. Certain operating conditions that require more frequent maintenance intervals have been noted. In positive pressure inlet conditions where suction or lift is not required, fluid system maintenance may be extended.

Adhering to the recommended preventative maintenance schedule along with periodic inspection of the pump will ensure continued efficient operation and overall reliable pump performance.

It is recommended that the Preventive Maintenance Record (Section 4.1.a) be copied, maintained and kept with this unit for future reference.

Maxim 50E and 50U

Replacement			Inspection				Component / Comments
6 Month	1 Year	2 Year	3 Month	6 Month	1 Year	2 Year	
		X					Quick Exhaust Seal
		X					Muffler Media
		X					Shaft and Shaft Seal
		X					Check Balls and O-Rings
						X	Check Seat, Suction Check, Discharge Check
		X					Diaphragms
		X					Check Plug Seals

4.1.a Preventive Maintenance Record

Company Name: _____

Company Address: _____

Product: _____ Serial Number: _____

Date: _____ Tech: _____ Notes: _____

Date: _____ Tech: _____ Notes: _____

Date: _____ Tech: _____ Notes: _____

Date: _____ Tech: _____ Notes: _____

Date: _____ Tech: _____ Notes: _____

Date: _____ Tech: _____ Notes: _____

Date: _____ Tech: _____ Notes: _____

Date: _____ Tech: _____ Notes: _____

Date: _____ Tech: _____ Notes: _____

Date: _____ Tech: _____ Notes: _____

Date: _____ Tech: _____ Notes: _____

Date: _____ Tech: _____ Notes: _____

Date: _____ Tech: _____ Notes: _____

Date: _____ Tech: _____ Notes: _____

Date: _____ Tech: _____ Notes: _____

Date: _____ Tech: _____ Notes: _____

Date: _____ Tech: _____ Notes: _____

Date: _____ Tech: _____ Notes: _____

Date: _____ Tech: _____ Notes: _____

Date: _____ Tech: _____ Notes: _____

Date: _____ Tech: _____ Notes: _____

Date: _____ Tech: _____ Notes: _____

Date: _____ Tech: _____ Notes: _____

Date: _____ Tech: _____ Notes: _____

4.2 RECOMMENDED SPARE PARTS

KR50EU-00-A Spares Rebuild Kit, which includes:

<u>Part No</u>	<u>Qty</u>	<u>Description</u>
KM50EU-00-A	1	Maintenance Kit Includes: (2) 1900B0016 Quick Exhaust Port (2) 98003047 Quick Exhaust Seal (2) AK205 Muffler Assembly
KD50-00-A	1	Diaphragm Kit Includes: (4) 1700C0047 Diaphragms (2) W0151 Fiber Optic Target
98001415	4	Check Ball
98002334	4	O-ring, PTFE
98003079	2	Shaft Seal
AK004	1	Shaft, Maxim 50
AK153	2	Check Cap Seal
AM082	2	Seal, Adapter port In/Out

In critical applications, a spare pump is recommended to minimize possible down time during service intervals.

4.3 TOOLS

The following tool kit is recommended as standard service equipment.

KT50-00-B Tool Kit, which includes:

<u>Part No</u>	<u>Qty</u>	<u>Description</u>
98003108	1	Torque Wrench, 30-150 ft/lb., 1/2" Drive
98003150	1	Tool Case, w/Foam, M50
98003305	1	Handle, Soc, 1/4" Drive
98003306	1	Wrench, Adj, 15/16"
T0126	1	Tool, Shaft Insert
T0129	1	Tool, Strap Wrench
T0132	1	Rebuild Fixture
T0144	1	Tool, Wedge, Head Removal, Cleaning Tool
T0146	1	Tool, Pin, 3/4x1/4 Drive
T0147	1	Tool, Pin, 1x1/4 Drive
T0148	1	Tool, Pin, 1/2x1/4 Drive
T0149	1	Tool, Pin, Optic Cap, 3/4

4.4 PARTS ILLUSTRATION

□ BORDERS REPRESENT FLUID CONTACT AREAS

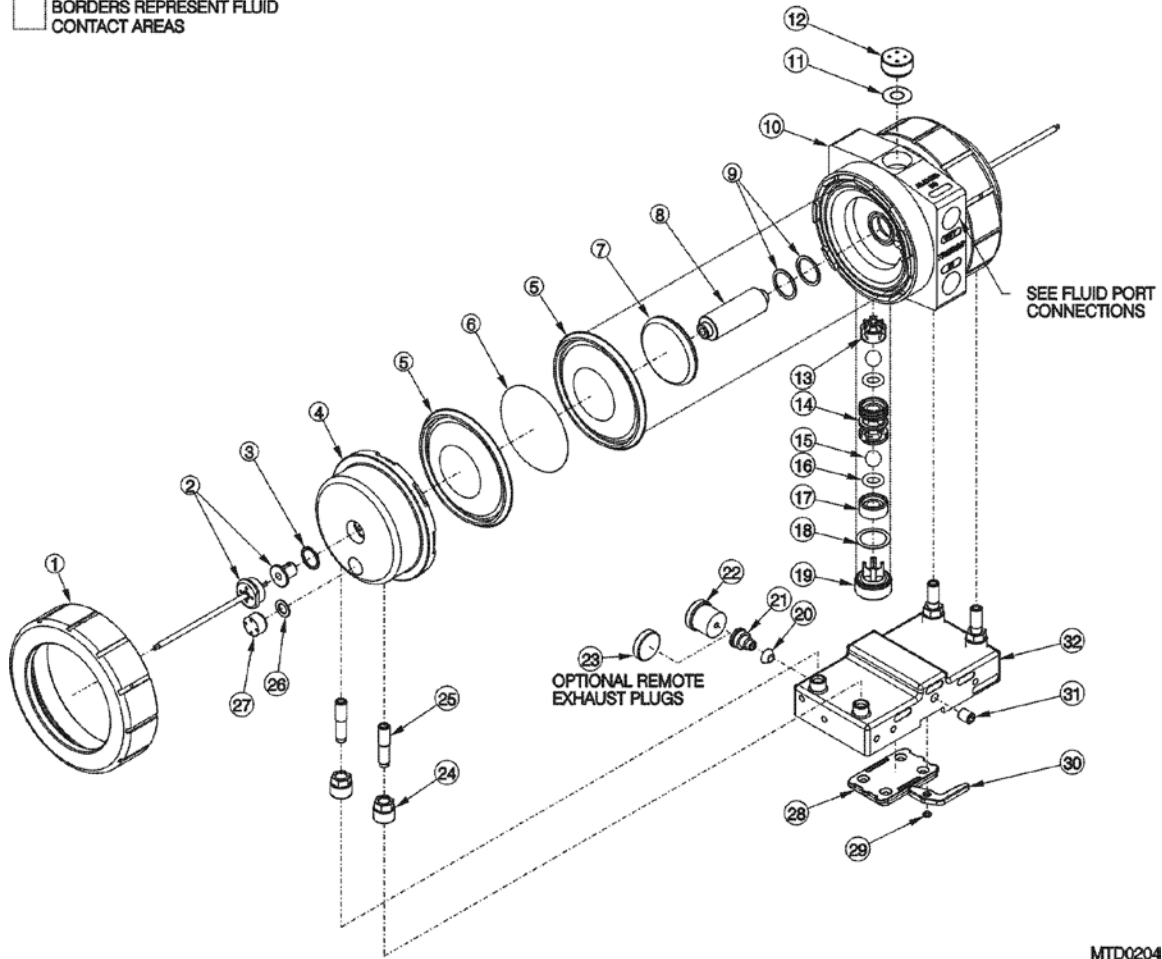

MTD0204

4.5 PARTS LIST

ILL NO	PART NO	QTY	DESCRIPTION	PM YEAR #	MATERIAL
1	AK003-01	2	Union Nut		PVDF (PP optional)
2	DP-C-12	2	End-of-Stroke Probe (E Model only)		PTFE, Kynar, Acrylic, PE
3	W0154	2	Probe Seal (included in DP-C-12) (E Model only)		PTFE
4	AK124	2	Head		PP
5	1700C0047	4	Diaphragm	2	PTFE
6	W0151	2	Fiber Optic Target	2	PTFE
7	1700B0041	2	Push Plate		PTFE
8	AK004	1	Shaft	2	PFA
9	98003079	2	Shaft Seal	2	PTFE
10	AK065	1	Body		PTFE
11	AM084	1	Surge Port Seal		PTFE
12	AM075	1	Damper Plug		PTFE
13	AK026	2	Discharge Cage Check		PTFE
14	AK068	2	Suction Check		PTFE
15	98001415	4	Check Ball	2	PTFE
16	98002334	4	O-Ring	2	PTFE
17	AK066	2	Suction Seat		PTFE
18	AK153	2	Check Port Seal	2	PTFE
19	AK149	2	Suction Plug		PTFE
20	98003047	2	Quick Exhaust Seal	1 & 2	Viton
21	1900B0016	2	Quick Exhaust Port	1 & 2	UHMW
22	AK205	2	Muffler Assembly	1 & 2	PP
23	1900B0072	2	Exhaust Plug (Optional for remote exhaust)		PP
24	98003277	4	Transfer Tube Nut		PP
25	AK182	4	Transfer Tube		PFA
26	AM037	2	Leak Port Seal		PTFE
27	AM035	2	Leak Port Plug		PTFE
28	AK088	1	Mounting Base		PP
29	98003071	1	Screw, PP		PP
30	AK108	1	Locking Lever		PP
31	98003080	2	1/4 NPT Fitting		PP
32	AK075	1	Control Base		PP

4.6 CLEAN-UP

To help remove potentially dangerous chemicals prior to service or shipment, the pump should be flushed with DI water or disassembled and thoroughly cleaned. Allow DI water to flush through the inlet and out the outlet to prevent pressure build up.



CAUTION: When handling pump wear appropriate personal protection gear, including safety glasses.

4.7 DISASSEMBLY

During the life of the pump it will be necessary to perform certain preventative maintenance procedures to ensure its continued high performance. This section and the next (4.8 Assembly) are provided for the user's convenience in disassembly and re-assembly procedures.

- Loosen and remove probe caps (Probes included with E Model only) from heads using 3/4" slotted pin tool.
- Remove probe assemblies (Probes included with E Model only) from heads.
- Remove seals.
- Loosen quick grip nuts on the transfer tubes from the pump base using 13/16" open-end wrench.
- Remove pump assembly from the pump control base.
- Immerse or flush the pump assembly using DI water and a neutralizing agent.
- Install mounting fittings in pump adapter ports and lock body into bench mounting fixture. **NOTE:** Securely attach mounting fixture to work surface using hardware provided.

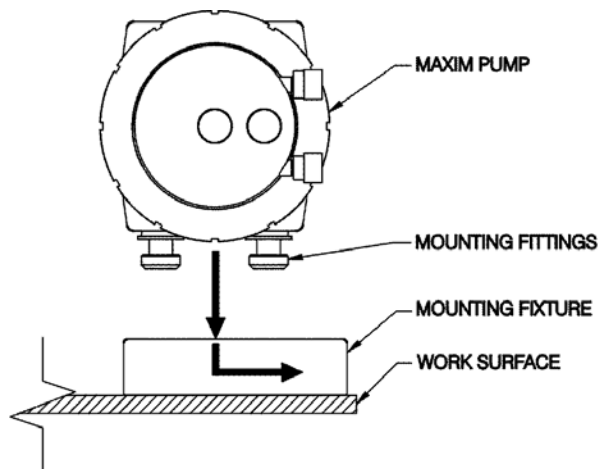

MTD0330

Figure 4-1

- Remove the transfer tubes from pump heads (using latex gloves).

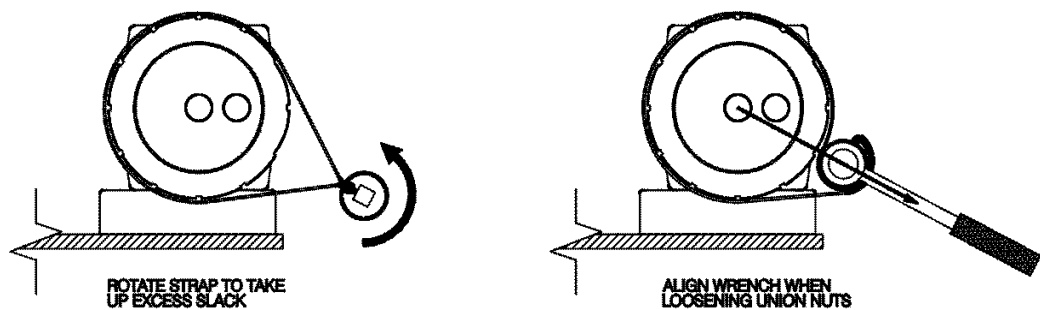

MTD0331

Figure 4-2

- Using strap wrench, turn union nuts counter-clockwise to remove.
- Remove head and check diaphragms for cracks or cuts.
- To remove diaphragms; slit diaphragm with a sharp knife and pull the diaphragms from the grooves. **(Do not pry on diaphragm seal groove, as this will damage the sealing surface.)**

- Unscrew push plate from the shaft in a counter-clockwise direction. Pull other push plate and shaft from pump body.

ATTENTION: Following disassembly, parts should be thoroughly washed and be free from chemical residue for handling purposes.

4.7.a Body Disassembly

- Remove suction plugs and seal on bottom of pump body using 1" pin tool.
- Remove suction seat using 1" pin tool.
- Remove ball and O-ring.
- Unscrew suction check using 1" pin tool turning it counter-clockwise.
- Remove second set of O-rings and balls and pull out discharge check cage.
- Remove shaft seals from pump shaft seal groove in the center of the shaft bore using the tip of a razor knife. Take care not to damage the shaft bore. NOTE: Do not reuse seals.
- Remove damper plug and seal using 3/4" pin tool.

4.7.b Control Base Disassembly

- Unlock control base from quick-change mount by pulling out lever on front of base to unlock mount. Then slide base back until it stops. Lift base off mount.
- Using pH test strips evaluate whether base has any contamination in air passages especially the muffler area. If present, neutralize using best methods prior to disassembly.
- Unscrew and remove muffler assembly from each chamber using the 1" pin tool.
- Unscrew and remove quick exhaust port in each chamber using the 1/2" pin tool.
- Remove quick exhaust seals from cavity.

4.7.c Cleaning

- Gently spray clean or dunk rinse all components with DI water to remove any trace materials remaining after disassembly.

4.8 ASSEMBLY

Prior to beginning assembly, inspect all parts to ensure they are clean and dry. Wear clean protective gloves. Precautions should be exercised to prevent contaminating any of the air chamber surfaces with chemicals during handling.

4.8.a Control Base Assembly – Quick Exhaust

- Insert the quick exhaust seal as shown below.
- Insert the quick exhaust port in each head as shown using the 1/2" pin tool, torque to 20in-lbs.

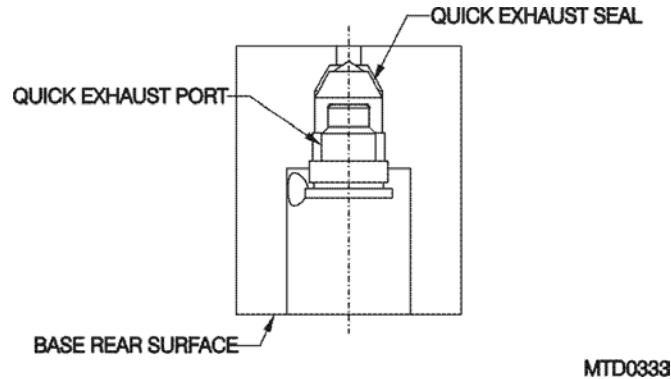
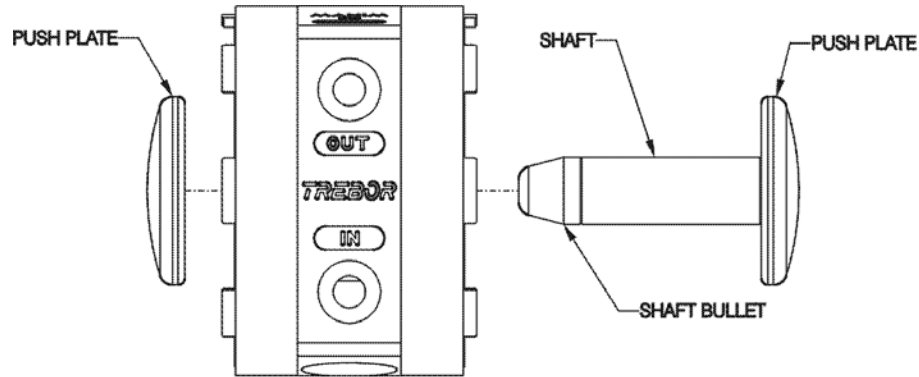

Figure 4-3

- Install muffler assembly using the 1" pin tool, torque to 40in-lbs.

4.8.b Body Assembly

- Install seal and damper plug into body using 3/4" pin tool, torque to 50in-lbs.
- Remove pump from assembly fixture.
- Turn pump upside down to access check bores.
- Install discharge check cage into bore making sure small end fits into relief in bottom of bore.
- Drop ball into check cage, then O-ring.
- Install suction sleeve into the bore; tighten using 1" pin tool. Tighten until engagement with O-ring is achieved, then unthread the sleeve a quarter turn. **Do not** over tighten as damage may occur.
- Install second ball into check cage, then O-ring.
- Install suction seat using the 1" pin tool. Tighten until engagement with O-ring is achieved, then unthread the seat a quarter turn.
- Install check seal onto check bore shoulder and thread suction plug into bore using 1" pin tool, torque to 60in-lbs.
- Repeat for the second bore.
- Install two shaft seals in shaft bore groove with slits 180° apart.
- Thread push plate onto main shaft until engagement with the shaft shoulder is achieved. Additionally apply a 1/4" turn to ensure proper installation.
- Thread shaft onto shaft insert tool and insert shaft into bore.



MTD0351

Figure 4-4

- Remove shaft insert tool and thread second push plate until engagement with the shaft shoulder is achieved. Additionally apply a $\frac{1}{4}$ " turn to ensure proper installation.

4.8.c Final Assembly

- Reattach pump to assembly fixture.
- Attach union nut to one side of pump body (hand tight). Do not install diaphragm on this step. This will protect body during initial pump assembly.
- Remove pump from the assembly fixture.
- Place pump body with union nut down and place two diaphragms, removing all air from between diaphragms, with "V" groove point toward the body.
- Install head on body. Note tab alignment and orientation of transfer tube ports in head.
- Install union nut on pump while gently pressing down on the head to engage tabs in head and body, spin union nut down hand tight.
- Turn pump over and remove union nut to install diaphragms.
- Repeat diaphragm, head and union installation.
- Lock body into mounting fixture.
- Using strap wrench, torque union nuts slowly to 75 ft-lbs with the wrench at $90^\circ \pm 15^\circ$ to the nut's surface as shown.

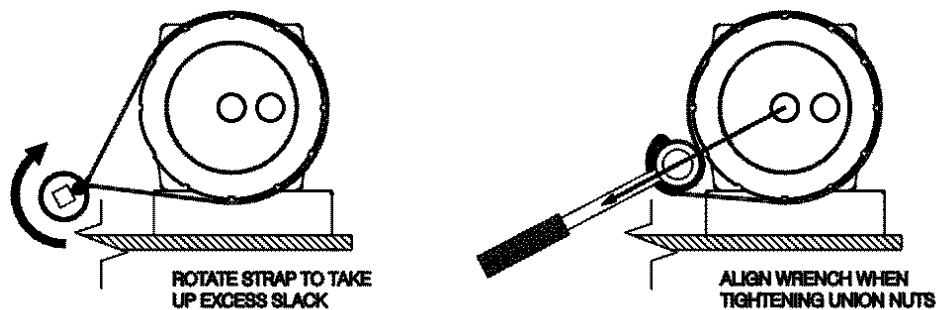

MTD0352

Figure 4-5

- Wrap each transfer tube with 3 wraps of Teflon tape and reinstall into the head ports using latex gloves for added grip. Leave a protrusion height of 2" for each transfer tube.
- Position control base on mounting base, slide base forward, use locking lever to secure.
- Ensure that the ferrule of the quick grip nut is inserted into the transfer tube port of the base. Place the gripper seal on top of the ferrule with the tapered end facing up.
- Loosely attach quick grip nuts to transfer tube ports on control base taking care not to dislocate the ferrule and gripper seal.
- Install pump onto control base by inserting transfer tubes in pump into quick grip nuts on control base.
- To secure pump to control base, tighten quick grip nuts one (1) full turn past hand tight using 13/16" wrench.
- Reinstall seals, optic probes (Probes included with E Model only), and optic probe caps (E Model only) into heads using the 3/4" slotted pin tool. **(Do not twist optic fibers as they could be damaged.)**
- Reconnect both air supply and fluid lines.

4.9 TESTING

4.9.a Performance Test

- Start with air regulator at low (< 15 psi) pressure setting.
- Pump must prime once pressure is increased
- 60 psig Supply Pressure
- Check for fluid leaks, listen for air leaks, check for irregularity

4.9.b 80/80 Leak Test

- While cycling the pump supply 80 psi air
- Close the discharge valve to create deadhead conditions
- Leave at this condition for 2 minutes and check for air or fluid leaks
- If a leak is witnessed, repair/replace components as necessary
- Open discharge valve and expel the remaining DI water
- Prepare the pump for drying

4.9.c Dry Pump

- Connect vacuum hose to discharge line
- Connect purge line to fluid inlet
- 60 psig Supply Pressure
- Cycle pump & vacuum dry by rotating pump side to side for 30 seconds.
- Turn off Air Supply and allow the pump to purge for 5 minutes.

4.9.d Dry Suction

- 20 psig Supply Pressure Target
- Record Suction Value
- Target = 12in-Hg

4.10 MAXIM PUMP LADDER LOGIC CONTROL EXAMPLE

The following sample ladder logic is provided as a reference to assist in customer programming of a PLC for either pneumatic oscillation or optic end-of-stroke pump control. Your PLC may require different ladder logic.

4.10.a Oscillator Control (No Probes Required)

```

M8002 IS ON DURING 1RST SCAN
!
M8000 IS ON WHEN PLC IS POWERED & RUN MODE
!
!M8002
!
0 +-I I-----[ SET
M8028 ]+
!ON
10MS !
!PLS
CLOCK !
!
!
!M8000 XO
K100 !
3 +-I I---I I-----
(T42 )+
!PLC CTRL
OSC !
!ON
SPEED !
!
!
!M11 Y1
!
8 +-I I----- (
)---+
!ON A
PUMPA !
!
!
!M12 Y2
!
10 +-I I----- (
)---+
!ON B
PUMPB !
!
!

```

```

!T42
!
12 +-I I-----[ALT
M10 ]+
!OSC
!
!SPEED
!
!
!M10
!
16 +-I I-+-----[SET
M11 ]+
!      !
A !
!      !
!      !
!      !
M12 ]+-----[RST
!
B !
!
!
!M10
!
19 +-I/I-+-----[SET
M12 ]+
!      !
B !
!      !
!      !
!      !
M11 ]+-----[RST
!
A !
!
!
!T42
!
22 +-I I-----[RST
T42 ]+
!OSC
OSC !
!SPEED
SPEED !
!
!X0
!
25 +-I/I-+-----[RST
M11 ]+
!CTRL !
A !

```



```

      !SENSA   T41
PLSA  !
!
!
!           !           (ignore signal until
!           !X2         minimum cycle time)
!
11  +-I I-----I I-----[PLS  M2
]+
      !SENSB   T40
PLSB  !
!
!
!
!           !M11                                     Y1
14  +-I I-----[
)---+
      !ON A     !
PUMPA !
!           !           (min 150ms cycle)
K15  !
!           +-----
(T40)-!
!
!           !M12                                     Y2
16  +-I I-----[
)---+
      !ON B     !
PUMPB !
!           !           (min 150ms cycle)
K15  !
!           +-----
(T41)-!
!
!           !M1
18  +-I I-+-----[SET
M11 ]+
!PLSA !                                     ON A  !
!
!
!
!
!
!           +-----[RST
M12 ]+
!
B  !                                     ON

```



```

!M8002
!
  0 +-I I-----[SET
M8028]+
!ON
MS !
!PLS
CLOCK !
!
!
!M8000
K100 !
  3 +-I I-----
(T42 )+
!PLC ON
OSC !
SPEED !
!
!X1
!
  7 +-I I-----[PLS M1
]+
!SENSA
PLSA !
!
!X2
!
 10 +-I I-----[PLS M2
]+
!SENSB
PLSB !
!
!
!M11
!
 13 +-I I-----[PLS M1
)---+
!ON A
PUMPA !
!
!
!M12
!
 15 +-I I-----[PLS M2
)---+
!ON B
PUMPB !
!
!
!M1 T40
!

```

```

17 +-I I-+-I I-+-----[ SET
M11 ]+
A ! !PLSA !TIMEA! ON
! ! !
! ! !
! !T42 ! !
!
+-I I-+ +-----[ RST
M12 ]+
B ! !OSC ON
! !SPEED
! !
! !M2 T41
!
22 +-I I-+-I I-+-----[ SET
M12 ]+
B ! !PLSB !TIMEB! ON
! ! !
! ! !
! !T42 ! !
!
+-I I-+ +-----[ RST
M11 ]+
A ! !OSC ON
! !SPEED
! !
! !M11
K15 !
27 +-I/I-----
(T40 )+
!ON A
TIMEA !
! !
! !
! !M12
K15 !
31 +-I/I-----
(T41 )+
!ON B
TIMEB !
! !
! !
! !M0
!
35 +-I I-+-----[ RST
T42 ]+

```

```

!      !
OSC    !      !
!      !
SPEED !      !
!      !
!      !M1    !
!      !
!      +-I I-+
+      !PLSA !
!      !      !
!      !      !
!      !      !
!      !      !
!      !T42  !
!      +-I I-+
+      !OSC
!      !SPEED
!      !
!      !X0
!      40 +-I/I-+-----[RST
M11  ]+
!CTRL !
A   !
!      !
!      !
!      !
!      !
!      +-----[RST
M12  ]+
!
B   !
!      !
!      !
!      !
!      !
!      43 +-----
[END ]+

```

5 TROUBLESHOOTING

Pump Will Not Start, Fails to Operate

Cause:

- Insufficient air pressure.
- Air lines not attached properly.
- Insufficient air volume (low supply pressure during running).
- Fluid discharge line blocked. Downstream valve closed, filter plugged or other obstruction.
- Probe failure (E Model only).

Solution:

- Must be minimum 15 psi at pump air hook-up.
- Check external controller.
- See Performance Charts (3.1) for requirements. Check for both regulator and control valve capabilities.
- Remove obstruction.
- Check fiber optic probes for correct operation. Check external controller. Check for excessive bends in fiber optic cable. Clean or trim fiber optic cable at the sensor.

Bubbles in Fluid Discharge

Cause:

- Leaking fluid inlet fitting.
- Leaking main seal.
- Pump inlet line pressure reached saturation point (due to high suction requirement).
- Ruptured (perforated) diaphragm.
- Check bore caps leaking.

Solution:

- Replace adapter seal.
- Tighten union nut to 75 ft-lbs. or replace diaphragms, and check head and body seal grooves for nicks or scratches.
- Increase diameter of suction supply line (reduces restriction). Reduce output flow.
- Replace diaphragms.
- Tighten check bore caps or replace seals.

Fluid Leaks

Cause:

- Union nut torque not enough to create seal.
- Leaking main seal.
- Check bore cap.
- Ruptured diaphragm(s) can result in fluid leaks through air exhaust port.

Solution:

- Tighten union nuts to 75 ft-lbs.
- Replace diaphragms. Check head and body seal grooves for nicks or scratches.
- Tighten, or remove and replace seal.
- Replace diaphragms, and any parts that may have been damaged by fluid exposure.

Erratic Cycling

Cause:

- Air line or fittings leak in external controller.
- Suction line restricted (cavitation).
- Quick exhaust seal not sealing.
- Check ball(s) not seating.
- Transfer tube leaking.

Solution:

- Replace tubing or tighten fittings. Replace controller.
- Reduce fluid restriction.
- Check for particles between seal and port. Replace seal.
- Check O-rings for damage; replace if necessary. Make sure check balls move freely in sleeves.
- Tighten transfer tubes and quick grip nuts as described in Section

6 WARRANTY



See the Trebor Standard Limited Warranty at
www.idex-hs.com/support/trebor/downloads/TreborStandardLimitedWarranty_02-07.pdf

7 CONTACT INFORMATION

7.1 GENERAL CONTACT INFORMATION

Web: www.idex-hs.com
Phone Number: (801) 561-0303
Toll Free Number: (800) 669-1303
Fax Number: (801) 255-2312
Email: treborinfo@idexcorp.com
treborsales@idexcorp.com
Address: Trebor International
8100 South 1300 West
West Jordan, Utah 84088 U.S.A.

7.2 TECHNICAL SUPPORT

Email: treborservice@idexcorp.com
Phone Number: (801) 244-6156

7.3 REGIONAL REPRESENTATIVES

Web: www.idex-hs.com/about/distributors/trebor_distributors.aspx