

SS95-X

Surge Suppressor

Operation / Maintenance Manual

CONTENTS

1	INSTALLATION	3
1.1	UNPACKING	3
1.2	LOCATING / MOUNTING SURGE.....	3
2	MAINTENANCE	5
2.1	PREVENTIVE MAINTENANCE SCHEDULE.....	5
2.2	RECOMMENDED SPARE PARTS	5
2.3	TOOLS.....	5
2.4	PARTS ILLUSTRATION.....	6
2.5	PARTS LIST	6
2.6	CLEAN-UP.....	6
2.7	DISASSEMBLY	7
2.8	CLEANING	7
2.9	ASSEMBLY	7
	2.9.a Head Assembly	8
	2.9.b Final Assembly	8
3	WARRANTY 	9

1 INSTALLATION

1.1 UNPACKING

After unpacking, the Surge Suppressor should be checked for any damage that may have occurred during shipment. Damage should be reported to the carrier immediately.

The following items should be included within the shipping container:

<u>Qty</u>	<u>Item</u>	<u>Description</u>
1	SS95-X	SS95 Surge Suppressor
1	MSS95-X	Operation/Maintenance Manual

1.2 LOCATING / MOUNTING SURGE

- Run 1/8 bleed line to drain. In the event of a diaphragm failure fluid may flow through tube to drain.
- Connect air supply using 3/8" or larger air line. Air supply to Surge Suppressor must be equal to or greater than pump supply pressure.

NOTE: When connecting the SS95-X to an externally controlled pump, do not connect the SS95-X air supply via a tee from the pump. Connect to a separate continuous supply.

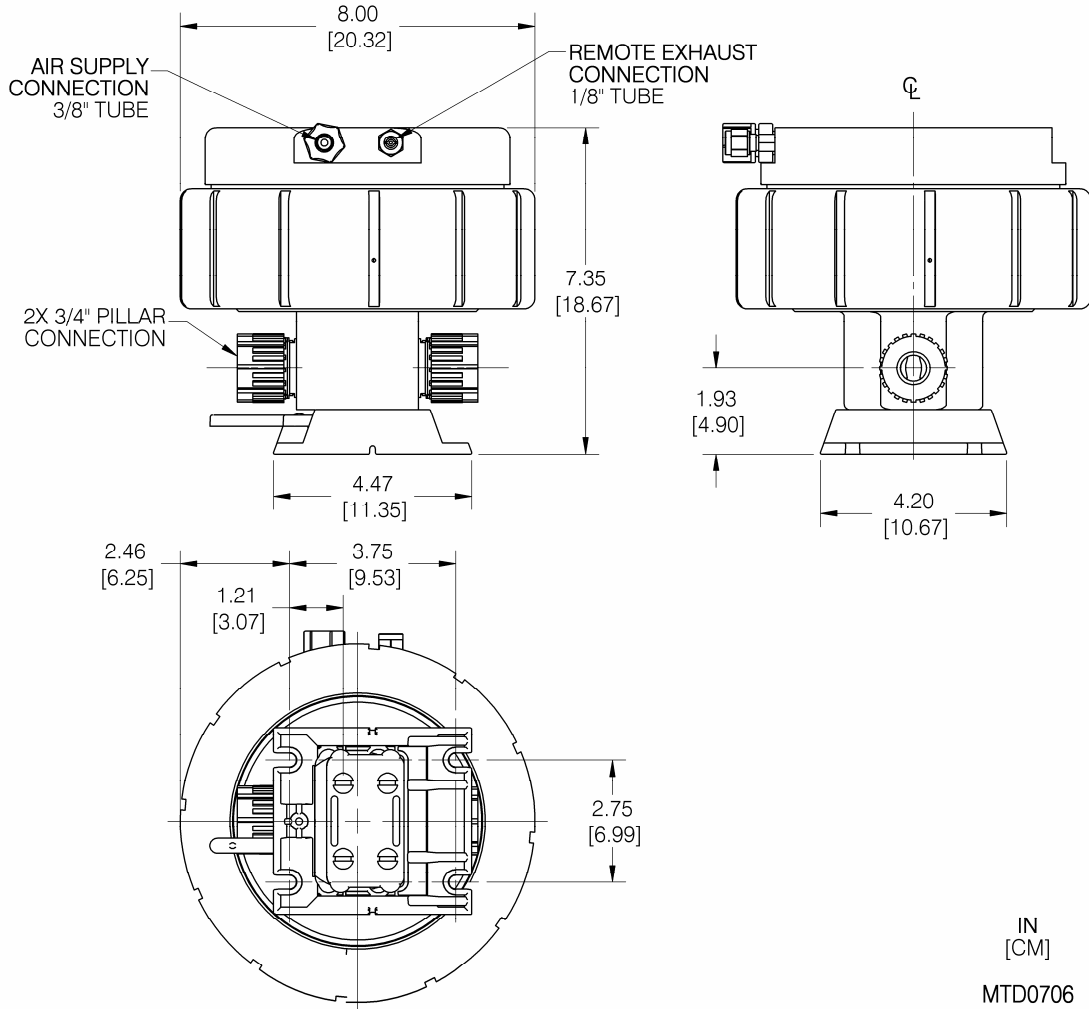

Figure 1-1

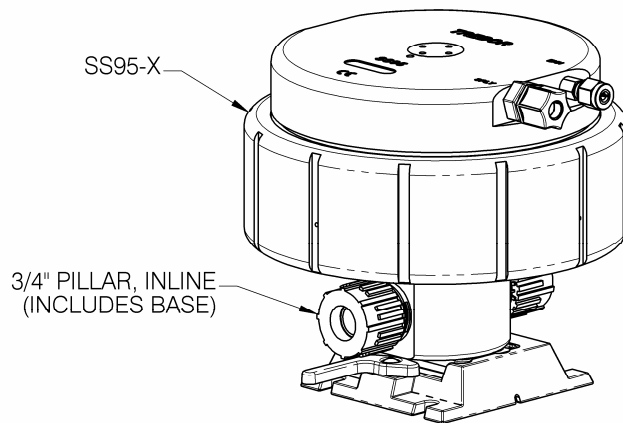

Figure 1-2

Available Options

Inline, 3/4" Super 300 Type Pillar®

2 MAINTENANCE

2.1 PREVENTIVE MAINTENANCE SCHEDULE

SS95-X Surge Suppressor

Replacement			Inspection			Component / Comments
1 Year	2 Year	4 Year	6 Month	1 Year	2 Year	
		X				Poppet Pilot Valves and Seats
		X			X	Diaphragms
				X		Union Nut Retorque

2.2 RECOMMENDED SPARE PARTS

KRSS95-00-A Spares Rebuild Kit, which includes:

<u>Part No</u>	<u>Qty</u>	<u>Description</u>
1700C0047	1	Diaphragm
98002450	1	O-ring
AK020	1	Pilot Poppet
AK030	1	Pilot Seal
AL023	1	Pilot Seat

2.3 TOOLS

Include:

<u>Part No</u>	<u>Qty</u>	<u>Description</u>
98003108	1	Torque Wrench, 30-150 Ft. Lb.
98003305	1	1/4" Drive Handle
T0129	1	Strap Wrench
T0146	1	3/4" Pin Tool
	1	Bench Vise

2.4 PARTS ILLUSTRATION

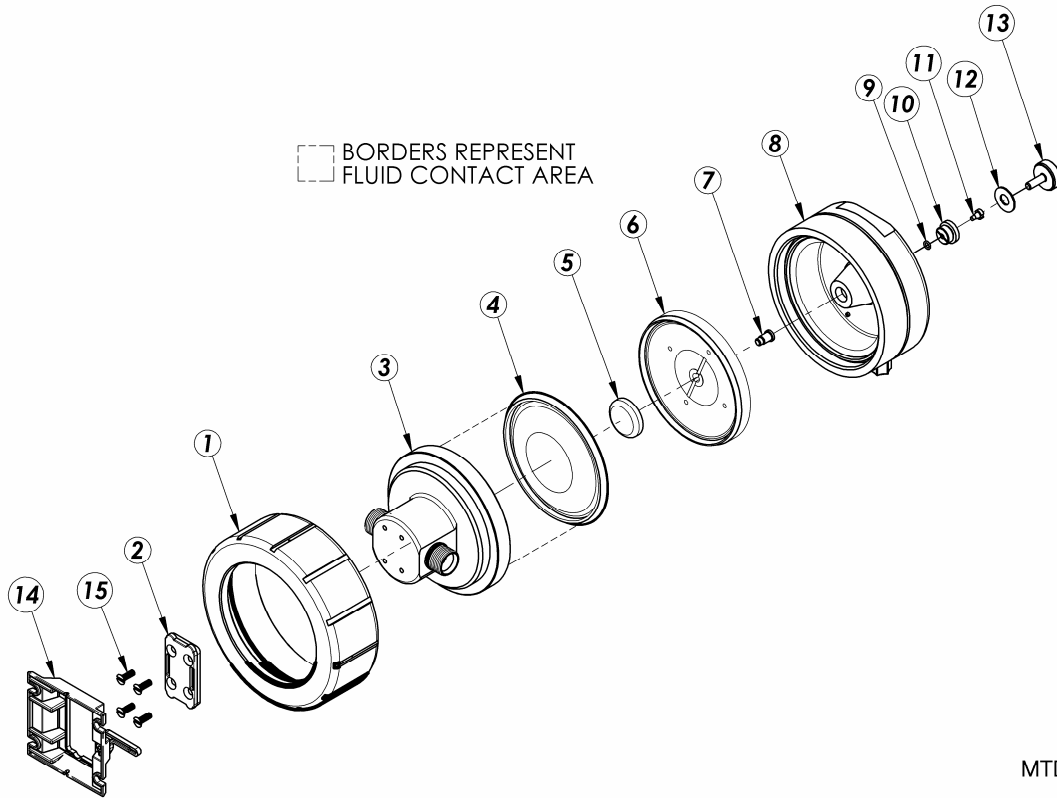

MTD0708

2.5 PARTS LIST

ILL NO	PART NO	QTY	DESCRIPTION	MATERIALS
1	AL003-01*	1	Union Nut	PVDF
2	AM022	1	Base, Mounting	PP
3	AL056	1	Body, Inline 3/4" Pillar Connection	PFA
4	1700C0047	1	Diaphragm	PTFE
5	J0093	1	Push Plate	PTFE
6	AL019	1	Support Plate	PTFE
7	AL014	1	Shaft	PFA
8	AL001	1	Head	PP
9	98002450	1	O-Ring	FFKM
10	AL023	1	Pilot Seat	PTFE
11	AK020	1	Pilot Poppet	PFA
12	AK030	1	Pilot Cap Seal	PTFE
13	AL004	1	Pilot Cap	PP
14	C0102	1	Base, Quick Release	PP
15	98003207	4	Screw, #4-20 X 3/4", FHSMS	G.F. PP
*			Available in other configurations	

2.6 CLEAN-UP

To help remove potentially dangerous chemicals prior to service or shipment, the surge Suppressor should be flushed with DI water or disassembled and thoroughly cleaned. Allow DI water to flush in and out to prevent pressure build up. Surge Suppressor can also be submerged in a rinse tank for clean up.

NOTE: When handling Surge Suppressor, wear appropriate personal protection gear, including safety glasses.

2.7 DISASSEMBLY

During the life of the Surge Suppressor it may be necessary to perform certain preventative maintenance procedures to ensure its continued high performance. This Section and Section 2.9 Assembly are provided for the user's convenience in disassembling and re-assembling the Surge Suppressor.

- Thoroughly clean/flush the Surge Suppressor using DI water (See Section 2.6 Clean-Up).
- Remove Surge Suppressor from Pump or fluid line.
- Remove safety tube fitting and air inlet fitting.
- Secure Surge Suppressor in Bench mounted vice across the flats in the head. To prevent aesthetics damage to head, use a protective barrier between vice and head.
- Remove union nut using the strap wrench, turning the nut counter clockwise to loosen.
- Pull the body away from the diaphragms. **NOTE:** Do not pry on body seal groove, this will damage the sealing surface.
- To remove diaphragms cut a slit in diaphragm with knife and pull the diaphragms from the support plate. **NOTE:** Do not pry on Support Plate seal groove, this will damage the sealing surface.
- Remove support plate from head.
- Remove push plate from shaft.
- Remove head from vice.
- Remove pilot cap and seal from head using 3/4" Pin Tool.
- Remove pilot poppet from head.
- Remove pilot seat from head using 3/4" Pin Tool.

NOTE: Following disassembly, parts should be thoroughly washed and be free from chemical residue for handling purposes.

2.8 CLEANING

Gently spray clean or tank rinse all components with DI Water to remove any trace of materials remaining after disassembly.

2.9 ASSEMBLY

Prior to beginning assembly, inspect all parts to ensure they are clean and dry. Damaged or worn parts should be replaced, along with all air and fluid seals. Wear clean protective gloves. Precautions should be exercised to prevent contaminating any of the air chamber surfaces with chemicals during handling.

2.9.a Head Assembly

- Thread pilot seat into head using 3/4". Light hand tight; **do not over tighten**, damage will occur.
- Install pilot poppet into pilot seat in head.
- Install seal and pilot cap into head tighten using 3/4" Pin Tool.

2.9.b Final Assembly

- Secure Head in bench mounted vice across the flats to prevent aesthetic damage use a protective barrier between vice and head.
- Install shaft through support plate; thread push plate onto shaft hand tight.
- Install assembled support plate into head.
- Install diaphragms onto support plate.
- Note V-groove orientation of diaphragms.
- Install body onto diaphragms.
- Thread union nut onto head using strap wrench turning clock-wise to tighten. Torque to 75 ft-lbs.

3 WARRANTY



SS95 SURGE SUPPRESSOR

TREBOR International, Inc. warrants to the purchaser of new equipment manufactured by TREBOR to be free from defects in material and workmanship when used for its intended purpose under normal operating conditions, and maintained according to the Operation/Maintenance Manual.

TREBOR's obligation under this warranty is limited to repairing or replacing, at TREBOR's option and at the TREBOR factory, any part or parts thereof which shall, within 2 years after delivery thereof to the original purchaser, be demonstrated to TREBOR's satisfaction to have been defective. This warranty may be transferred to subsequent owners. The warranty period is based on the original ship date from the factory. All warranty related freight costs shall be borne by the customer.

Excessive wear to pump components caused by pumping abrasive solutions or chemicals, as well as damage caused by ingesting foreign objects shall not be covered by this warranty.

This warranty shall not apply to any equipment which, in the judgment of TREBOR, shall have been repaired or altered outside TREBOR's factory in any way, so as to affect its performance or reliability; subjected to misuse, negligence or accident; or used other than in accordance with TREBOR's printed instructions.

There are no terms, conditions or warranties, expressed, implied or statutory, of merchantability, fitness, capacity, or otherwise, of the goods ordered, other than, or different from, the warranty set forth above. This warranty takes precedence over any other warranty, expressed or implied.

TREBOR neither assumes, nor authorizes any other party to assume for it, any liability in connection with said equipment except as set forth above.