

PURUS 20

Operation / Maintenance Manual

CONTENTS

1	INTRODUCTION	3
2	INSTALLATION	4
2.1	UNPACKING	4
2.2	UTILITIES / HOOK-UP	4
3	TEMPERATURE AND PRESSURE LIMITS	6
3.1	HIGH TEMPERATURE OPERATION	6
3.2	HIGH BACK PRESSURE OPERATION	6
4	OPTIONS	7
4.1	FLUID PORT CONNECTION OPTIONS.....	7
4.2	HOOK-UP WITH SURGE SUPPRESSOR.....	7
5	START-UP	8
5.1	PERFORMANCE CHARTS	8
6	INSPECTION AND MAINTENANCE	10
6.1	MAINTENANCE.....	10
6.2	PART REFERENCE ILLUSTRATION – P20.....	10
6.3	PART REFERENCE LIST – P20	10
7	TROUBLESHOOTING	11
8	WARRANTY 	12

1 INTRODUCTION

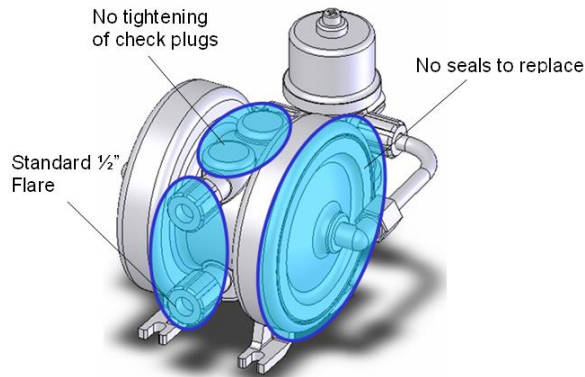

Figure 1-1: Injection Molded & Welded Design

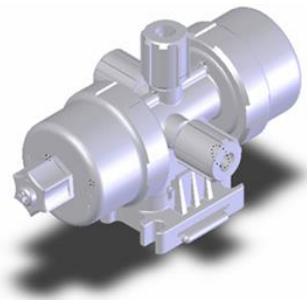

Figure 1-2: Optional PC7 Controller

PFA injection molded high purity disposable pump.

TREBOR'S Purus 20 diaphragm pump addresses maintenance, rebuild, and cost issues common in many chemical pumps by using an injection molded PFA design with minimal welded parts. This design (Figure 1-1) creates a reliable, disposable pump that costs less than many competitor pump rebuild kits. The Purus 20 provides peace of mind because of its purity, performance, and simplicity.

Purus pumps can be externally controlled or installed as a self-contained unit using TREBOR'S PC7 (Figure 1-2) air-powered pump controller that mounts on the Purus 20, as shown in (Figure 1-1).

Product Benefits

- Operating life exceeding 100 million cycles in many applications
- Excellent suction lift and priming capability
- No elastomer seals or gaskets to replace
- No metal parts to corrode or contaminate process
- Compact size
- 100% PFA/PTFE construction for the chemical compatibility and process purity
- FM4910 compliant
- Cleaned, assembled, and packaged in Class 1000 cleanroom
- CE Certified

2 INSTALLATION

2.1 UNPACKING

After unpacking, the pump should be checked for any damage that may have occurred during shipment. Damage should be reported to the carrier immediately.

NOTE: Although extensive efforts are made to deliver pumps to our customers completely dry, new pumps may contain residual moisture from their final DI water test.

The following items should be included within the shipping container:

Qty	Item	Description
1	PURUS 20	Purus 20 Pump
1	MP20	Manual, Purus 20 pump
1	PC7	PC& Pump Controller (optional)

2.2 UTILITIES / HOOK-UP

The pump is mounted using four ¼" (6mm) bolts. It is recommended that the pump be positioned within 15° from level to maintain self-priming ability and pumping efficiency. Allow sufficient room for tubing connectors.

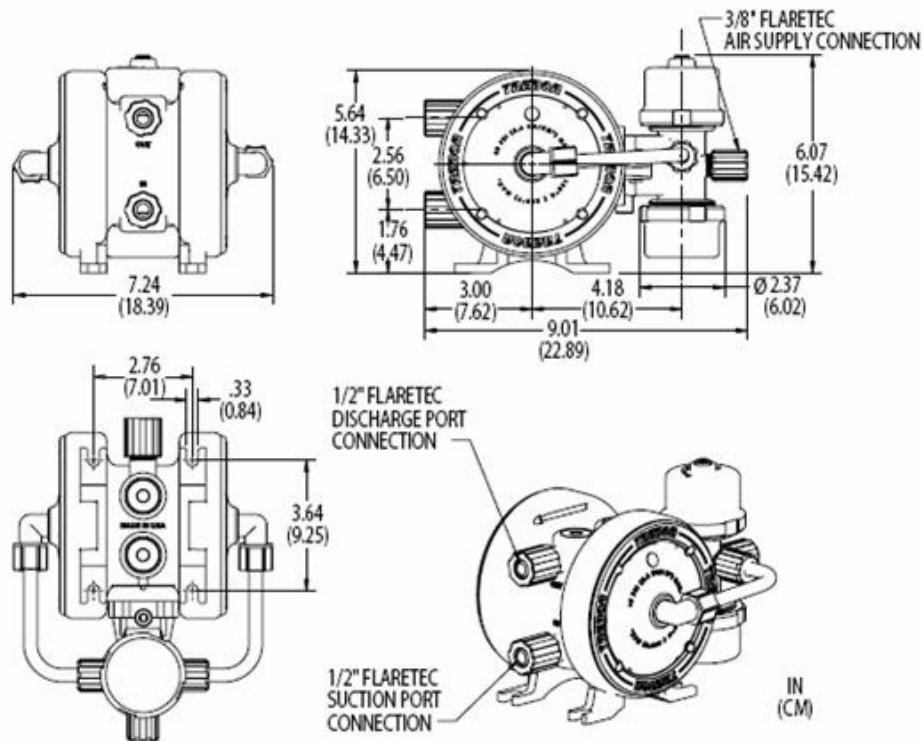

Figure 2-1: Dimensions (with mounted PC7 option & flare connection)

Air Inlet: 3/8" OD Tubing)

Air Supply: 20-80 PSIG (0.14 - 0.55 Mpa), clean dry air or inert gas

Fluid Ports: 1/2" Flaretek standard (other options available)

For maximum flow the following is recommended:

1. Maximize supply line diameter
2. Minimize supply line length
3. Minimize supply line restrictions (i.e. valves, fittings)

NOTE: It is recommended that a filter be placed on the discharge side of the pump.

ATTENTION: The pump should be operated with clean, dry air or nitrogen. Particulate, water and oils in the air supply can damage the pump.

3 TEMPERATURE AND PRESSURE LIMITS

3.1 HIGH TEMPERATURE OPERATION

The Purus 20 pump is molded out of virgin PFA. This enables high temperature operation under specific conditions. The maximum temperature will vary in relation to the supply pressure. Figure 3-1 shows Trebor's maximum recommended temperature for the pump. Exceeding the temperature for a corresponding supply pressure could cause the pump to develop leaks at the pump main seal between the air and fluid chambers.

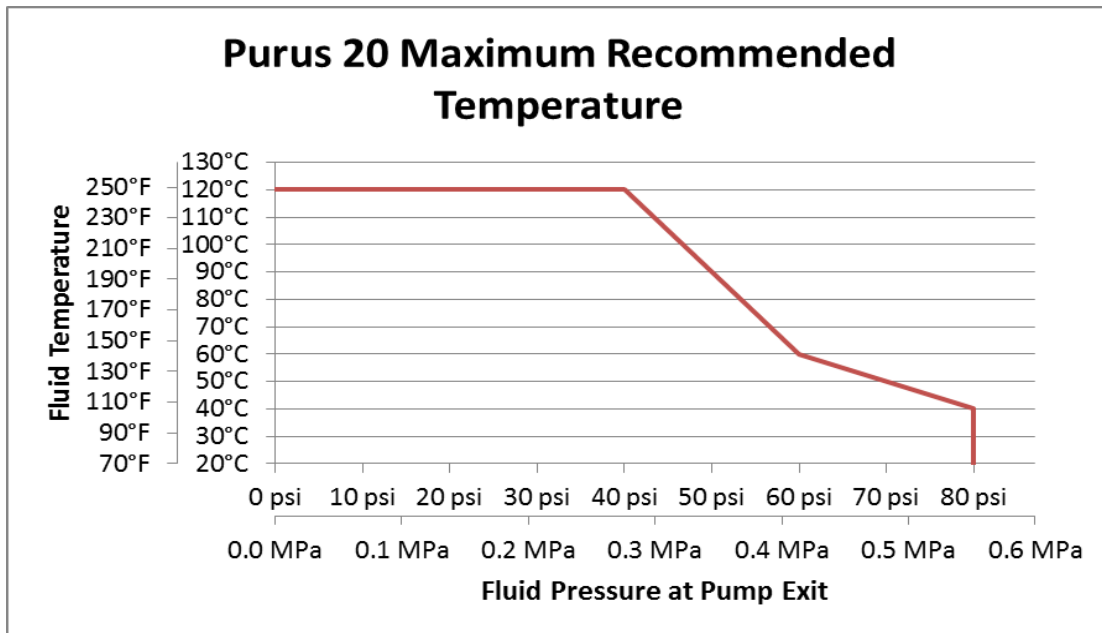

Figure 3-1: Purus 20 Recommended Temperature Curve

3.2 HIGH BACK PRESSURE OPERATION

Increasing the fluid outlet pressure, or back pressure, causes stress on the pump main seal. High back pressure, around 90% of the supply pressure, can cause the pump to develop leaks at the main seal. It is not recommended to run the Purus 20 pump at near dead head conditions.

High back pressure and elevated fluid temperatures can combine to increase the likelihood of pump failure due to a main seal leak. Higher temperature reduces the yield strength of PFA, while higher stresses are induced by the high back pressure. The combination of those two operating conditions can cause the main seal to unload, which can lead to a leak. Due to the potential variations in operating conditions, the typical range of material properties and the tolerance stack up, it is impossible to identify the exact points where main seal leaks become probable due to temperature/back pressure interactions.

4 OPTIONS

4.1 FLUID PORT CONNECTION OPTIONS

Additional options are available. Please contact Trebor Sales Department for details regarding available options.

- ½" Flaretek (standard)
- ½" Pillar, Super 300 (optional)

4.2 HOOK-UP WITH SURGE SUPPRESSOR

For surge suppression, Trebor International recommends the use of the SS40 inline surge suppressor. Consult factory for installation and performance specifications. Information also available at www.treborintl.com

NOTE: See Surge Suppressor Operation Manual for detailed installation instructions.

5 START-UP

- Open the fluid suction (IN) line valve, if necessary
- Open the fluid discharge (OUT) line valve, if necessary
- Pump air supply pressure should be regulated
- Operate pump at 20 psig initially to prime pump
- Increase pressure to attain desired flow, (not to exceed 80 psig)
- If the pump fails to start, refer to the troubleshooting section or contact Trebor for further assistance.

ATTENTION: Prolonged periods (>5 minutes) of running without fluid can damage critical internal pump parts.



CAUTION: When handling potentially dangerous fluids under pressure, the pump and its fittings should be placed in an enclosure away from operators.

5.1 PERFORMANCE CHARTS

Pumping capacity is a function of air supply pressure and volume, suction head, suction line restrictions, discharge head, discharge line restriction, and fluid specific gravity and viscosity.

Air Supply Pressure (PSIG)	Discharge Fluid Pressure (PSIG)	Flow (LPM)	Cycles Per Minute	Displacement cc Per Cycle	Air Consumption (CFM)
20	0	14	100	140	4.6
20	10	11	100	110	
40	0	18.5	180	103	6.0
40	20	12.5	104	125	
60	0	20	210	95	7.0
60	30	15	110	137	
80	0	21	218	97	8.0
80	40	16	132	121	

Table 5-1: Performance Chart

NOTE: Test information is based on specific conditions and limited sampling. Use for general reference only. This information is preliminary and may be changed at a future date.

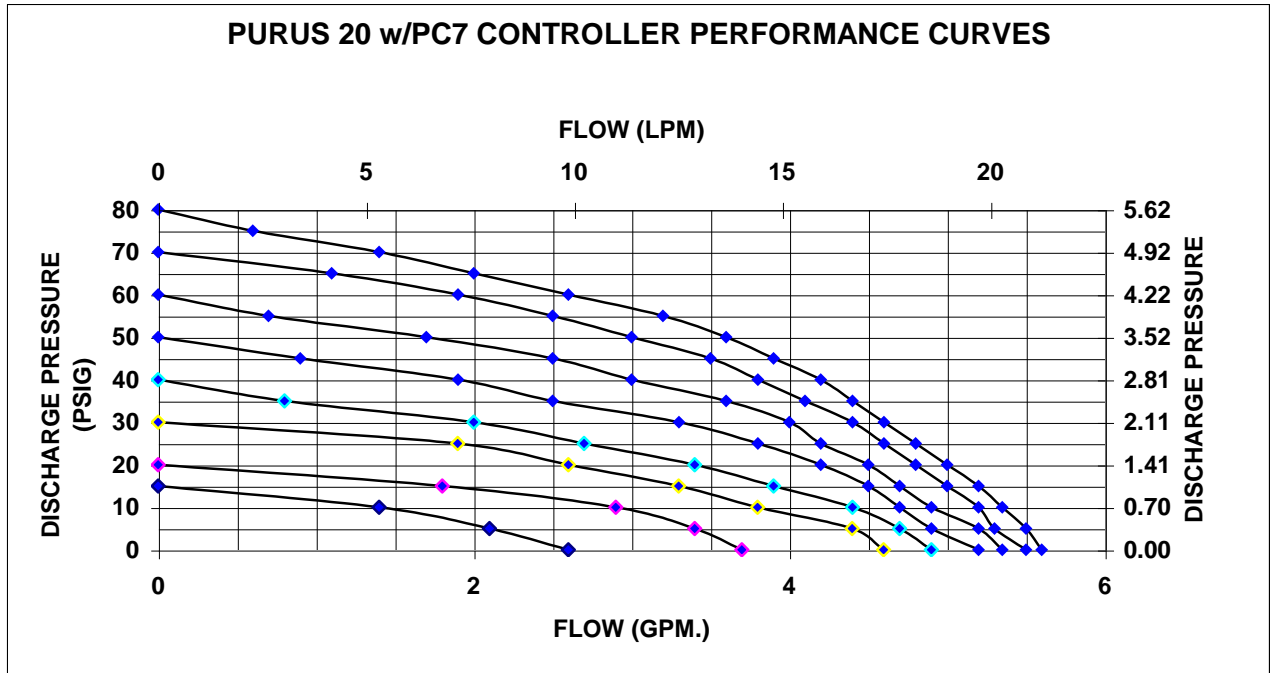

Figure 5-1: Pressure and Capacity chart

6 INSPECTION AND MAINTENANCE

6.1 MAINTENANCE

TREBOR'S PURUS 20 has no serviceable parts, due to its welded and sealed construction. Please neutralize and dispose of the pump accordingly or contact the factory regarding methods of recycling.

6.2 PART REFERENCE ILLUSTRATION – P20

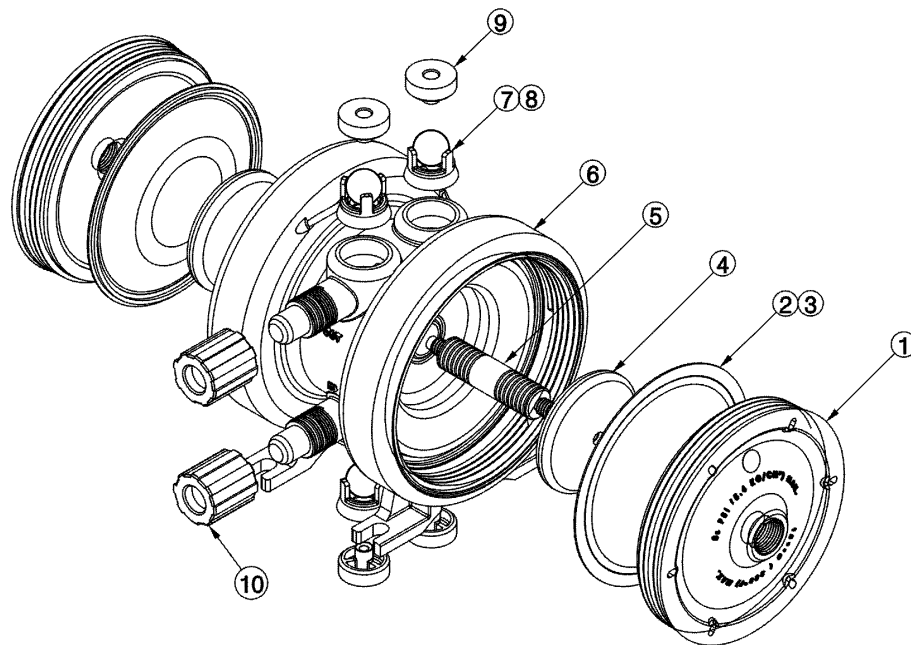

MTD0498

Figure 6-1 Exploded View

6.3 PART REFERENCE LIST – P20

ILL NO	QTY	DESCRIPTION
1	2	HEAD
2	2	DIAPHRAGM
3	2	MAIN SEAL
4	2	PUSH PLATE
5	1	SHAFT
6	1	BODY ASSY
7	2	SUCTION SEAT
8	4	CHECK BALL
9	4	CHECK CAP
10	2	1/2T FLR NUT

7 TROUBLESHOOTING

Pump Will Not Start, Fails to Operate

Cause:

- Insufficient air pressure
- Debris in shuttle valve
- PC7 (if applicable)

Solution:

- Increase regulated supply pressure or check control valves for proper operation.
Rotate PC7 speed control screw CW until it stops. Then readjust for correct speed (if applicable).
- Inspect/clean control valve assembly.
- Refer to PC7 Manual

Bubbles in Fluid Discharge

Cause:

- Inlet line fittings not tight
- Flow too high
- Diaphragm failure due to puncture

Solution:

- Check and tighten all fittings on the suction line feeding the pump.
- Under high flow conditions some fluids can cavitate releasing dissolved air bubbles.
- Contact Trebor Customer service for additional service recommendations. Replace pump.

Fluid Leaks

Cause:

- Weld failure of fluid pump
- Fluid leaking from suction or discharge connections

Solution:

- Replace pump (Non Serviceable)
- Inspect tubing and tighten fluid fittings.

Erratic Cycling

Cause:

- Debris in shuttle valve
- PC7 (if applicable)

Solution:

- Inspect/clean control valve assembly.
- Refer to PC7 Manual

8 WARRANTY

CE

See the Trebor Standard Limited Warranty at:
<http://www.treborintl.com/TechnicalSupport.aspx>