

PUMP MONITORING

Fiber Optic

Cycle Counting

Non
Metallic

Leak
Detection

Explosion Proof

CE

TREBOR's fiber optic probes and monitoring systems provide complete performance and diagnostic capability for your high purity pump. The use of fiber optic technology allowed us to design a non-metallic sensor that will not corrode in aggressive acid environments, and avoid the use of electrical terminations that may create explosion risk in volatile solvent applications. All probes are non-intrusive so they will not adversely affect pump performance or come in contact with your ultrapure fluids during normal operation.

Applications

- Cycle counting to verify pump is operating normally
- Set high and low cycle alarms to alert for possible run dry or plugged filter condition
- Total cycle count for establishing preventive maintenance intervals or large batch transfer
- End-of-stroke detection for remote air solenoid valve pump control
- Flow rate approximation within +/- 10%
- Leak detection to identify possible diaphragm puncture or failure
- Discharge line monitoring detects diaphragm breach or loose fittings on inlet side of pump

Construction

- All plastic construction - no metal parts to corrode, no metal contamination
- No electricity at detection point ensures safe pump operation
- All fiber optic leads come sheathed with PFA tubing for chemical resistance and strain relief
- Versatile probe options to suit most pump models and applications

FEATURES

TREBOR[®]
Pure Innovation

INTERNAL LEAK PROBE



The internal leak probes use a fiber optic signal to detect the presence of fluid in the air chambers of the pump in the event of diaphragm failure. Available for Maxim 25, Maxim 50, and Mega 960 pumps.

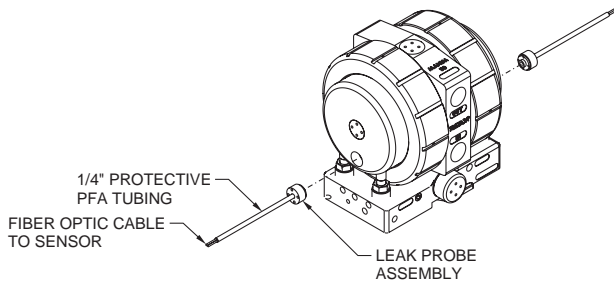

HOW IT WORKS

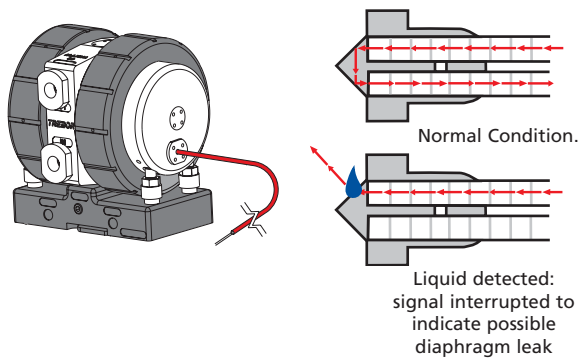

Part Number DP-L-20
Compatible with
Mega 960, Maxim 25 & 50
2 ea. Required per pump

EXTERNAL LEAK PROBE



The external leak probe uses a fiber optic signal to detect the presence of air in the fluid discharge line. The fiber optic probe is housed in a PTFE collar that is installed on the fluid discharge line of the pump. In the event of diaphragm failure or loose fittings, air bubbles will be present in the fluid discharge line of the pump. The fiber optic probe will detect air introduced into the fluid discharge line indicating a leak.

Part Number

- DP-L-06** 3/8" TUBE
- DP-L-08** 1/2" TUBE
- DP-L-12** 3/4" TUBE
- DP-L-16** 1" TUBE

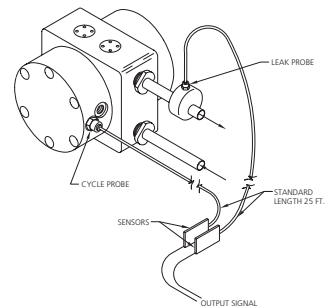

EXHAUST TEE PROBE

Part Number DP-L-22
Compatible with
Magnum 110/610, 620R
Requires remote exhaust kit

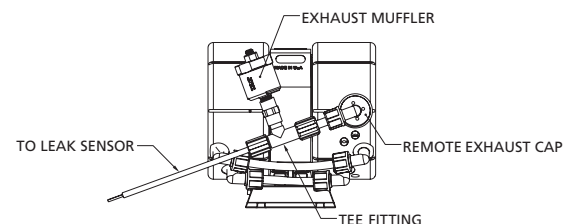

CYCLE PROBE



The pump cycle probe uses a fiber optic signal to register the movement of the shuttle spool. It is installed in the shuttle bore replacing the standard shuttle valve cap. The cycle probe can be used to monitor pump cycle rate for high/low cycle alarms, total cycles for maintenance purposes, or to approximate flow rate. It is non-intrusive, non-metallic, and non-electrical, providing safe cycle detection in any application.

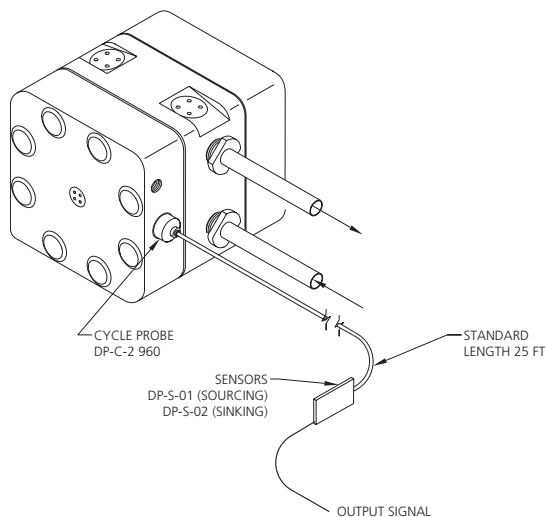

DP-C-1	110/610
DP-C-2	960/Maxim R
DP-C-10	610-NM
DP-C-11	620

Note: Requires one probe per pump, plus use of one fiber optic amplifier.

Accessories

Amplifier	DP-S-01 (Sourcing PNP) DP-S-02 (Sinking NPN)
Cycle Counter	M5 (Includes one amplifier)

END-OF-STROKE PROBE



End-of-stroke probes provide cycle counting and pump stroke control versatility for your application. A single probe can be installed and monitored as a means of cycle counting on Maxim E and 110/610 OSC pump models. This is accomplished by detecting the end position of the diaphragm stroke. Two probes may be used to operate an electronic external air control valve. This setup allows complete control and monitoring of pump speed and cycle counts. It also provides a drop-in replacement option for competitors' pumps that use external control valves.

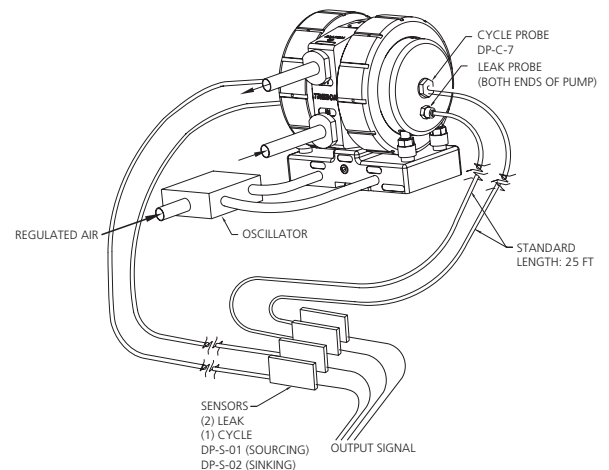

DP-C-6	110/610 OSC - 100°C
DP-C-7	Maxim E - 100°C
DP-C-12	Maxim E - High Temp. 180°C

Accessories

Amplifier	DP-S-01 (Sourcing PNP) DP-S-02 (Sinking NPN)
Cycle Counter	M5 (Includes one amplifier)
Leak Monitor	M10 (Includes two amplifiers)

M10 Leak Detector



Monitor pump air chambers to detect possible diaphragm puncture or fatigue failure.

- Includes 2 ea. optic amplifiers
- Low power 10-30VDC
- Requires leakprobe input (Sold Separately)
- Audible alarm
- LED leak indicator lights
- Relay output signal for remote air supply shutoff
- Wall mount or shelf rest ABS plastic housing
- 2-Year Warranty

M5 Cycle Counter



Display instantaneous flow rate or cycle rate. Includes cycle totalizer for PM notification.

- Includes 1 ea. optic amplifier
- Low power 10-30VDC
- Requires 1 ea. cycle probe input (Sold separately)
- Large LCD display for easy visual monitoring, including push button toggle between screens
- Non-metallic, explosion proof fiber optic stroke sensor allows monitor to be placed up to 4 meters away for safe pump operation
- Wall mount or shelf rest ABS plastic housing
- 2-Year Warranty

Fiber Optic Amplifier



DP-S-01 (Sourcing PNP)
DP-S-02 (Sinking NPN)

Amplifiers are required for use with each fiber optic probe to generate the light signal and convert information to an electronic output. This electronic signal may then be monitored by one of Trebor's pump monitors or by customer supplied PLC's or microcontrollers to offer a fully integrated system.

- 10-30VDC Power Required
- DIN rail mountable
- LED signal strength indicator
- Adjustable sensitivity control

Distributed by:



Trebor International
a unit of **IDEX Corporation**
8100 South 1300 West
West Jordan, Utah 84088 U.S.A.
Telephone: 801-561-0303
U.S.A. Toll Free: 888-763-7867
FAX: 801-255-2312
E-mail: treborsales@idexcorp.com
Internet: www.treborintl.com



ISO 9001:2000
FM 69754

TREBOR
Pure Innovation